

# P16 EVO

## en Tube-to-tube-sheet orbital weld head

Translation of original operating instructions and spare parts list

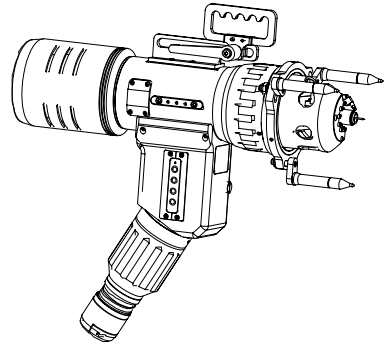

833 060 201 REV 00 | 0723



# Table of Contents

<b>1</b>	<b>About these instructions</b> .....	<b>6</b>
1.1	Warning messages .....	6
1.2	Further icons and displays.....	6
1.3	Further applicable documents.....	7
<b>2</b>	<b>Information and safety instructions for the owner</b> .....	<b>8</b>
2.1	Requirements for the owner-operator .....	8
2.2	Using the machine .....	9
2.2.1	Proper use.....	9
2.2.2	Machine constraints .....	10
2.3	Environmental protection and disposal.....	11
2.3.1	Information regarding the Ecodesign Directive 2009/125/EG .....	11
2.4	Personnel qualification.....	12
2.5	Fundamental information on operational safety.....	12
2.6	Personal protective equipment .....	14
2.7	Remaining risks .....	14
2.7.1	.....	14
2.7.2	Electric shock .....	14
2.7.3	Dangers through electromagnetic fields.....	15
2.7.4	.....	17
2.7.5	Damage to eyes through radiation .....	17
2.7.6	Risk of suffocation from an excessive amount of argon in the air.....	17
2.7.7	Poisonous vapors and substances.....	17
2.7.8	Tripping over wires and cables.....	18
2.7.9	Long-lasting physical damage through wrong posture.....	18
2.7.10	Injury through high weight .....	18
2.7.11	Burns and risk of fire .....	19
2.7.12	.....	20
2.7.13	Prick injury through pointed electrode and, if appropriate, cold wire.....	20
2.7.14	Danger of crushing through being caught in by moving parts.....	20
2.7.15	Injury through rotating machine parts.....	20
2.7.16	Danger of cuts at sharp edges .....	21
2.7.17	Risk of injury and fire due to defective components.....	21
2.7.18	Danger from incorrect handling of system components .....	21
2.7.19	General injuries through tools .....	22
2.7.20	.....	22
2.7.21	.....	22
2.7.22	.....	22

<b>3</b>	<b>Description .....</b>	<b>23</b>
<b>4</b>	<b>Application area .....</b>	<b>25</b>
<b>5</b>	<b>Technical specifications.....</b>	<b>29</b>
5.1	.....	31
<b>6</b>	<b>Transport and shipping.....</b>	<b>34</b>
6.1	Gross weight.....	34
6.2	Transport.....	34
<b>7</b>	<b>Commissioning .....</b>	<b>36</b>
7.1	Scope of delivery .....	36
7.2	Preparing initial operation .....	37
<b>8</b>	<b>Set-up and mounting .....</b>	<b>38</b>
8.1	Procedure .....	38
8.2	Fit cold wire conveyor unit (optional) .....	39
8.2.1	Replace wire coil .....	40
8.2.1.1	Remove wire coil .....	40
8.2.1.2	Insert wire coil and set wire feed rolls pressure .....	41
8.3	Hang the weld head on the spring balancer .....	44
8.4	Connecting the weld head to the power source.....	45
8.4.1	Connection sequence.....	46
8.4.2	Anschlussschema .....	47
8.5	Set up/replace the electrode.....	49
8.5.1	Grinding electrode .....	51
8.6	Fit centering unit .....	53
8.7	Clamp the weld head in the workpiece .....	54
8.8	Adjust welding diameter.....	55
8.8.1	Change mounting position of gas lens/nozzle on torch body.....	55
8.8.2	Finely adjust welding diameter .....	56
8.8.3	Adjust torch angle.....	58
8.9	Adjust welding gap .....	58
8.10	Position wire nozzle .....	59
8.11	Carry out the gas and cooling-liquid function test.....	61
8.12	Calibrating the motor.....	61
<b>9</b>	<b>Operation .....</b>	<b>62</b>

9.1	Weld mode.....	62
9.2	Aborting welding .....	63
9.3	Returning the weld head to home position .....	63
9.4	Removing the weld head from the workpiece.....	64
9.5	Manual wire feed and retraction.....	64
9.6	Preparing storage .....	65
<b>10</b>	<b>Maintenance and troubleshooting.....</b>	<b>66</b>
10.1	Instructions for care .....	66
10.2	Maintenance and care .....	66
10.2.1	Standard cleaning process.....	67
10.3	Troubleshooting .....	70
10.4	Replace wire guide nozzle.....	71
10.5	Replace wire guide hoses.....	72
10.6	Service and customer support .....	74
10.6.1	Customer support.....	74
10.6.2	Technical support & application engineering.....	74
10.6.3	Operator and service training.....	75
<b>11</b>	<b>ERSATZTEILLISTE / SPARE PARTS LIST .....</b>	<b>76</b>
11.1	P16 EVO   P16 EVO.....	78
11.2	P16 EVO mit KD   P16 EVO with KD.....	80
11.3	P16 EVO AVC   P16 EVO AVC .....	82
11.4	Grundkörper Übersicht P16 EVO m/o KD   Base body overview P16 EVO w/o Cold wire unit .....	84
11.4.1	Grundkörper m/o KD   Base body w/o KD.....	86
11.5	Grundkörper Übersicht P16 EVO AVC   Base body overview P16 EVO AVC.....	102
11.5.1	Grundkörper AVC   Base body AVC .....	104
11.6	Brennergruppe P16 EVO   Burner assembly P16 EVO .....	120
11.7	Brennergruppe P16 EVO AVC   Burner assembly P16 EVO AVC .....	124
11.8	Kaltdrahtzuführung P16-/P16 EVO AVC   Cold wire feed P16-/P16 EVO AVC.....	136
11.9	Drahtverstellungsgruppe P16 EVO, kpl.   Wire adjustment group P16, complete....	144
11.10	P16 EVO: Schläuche, Kabel und Anschlüsse   P16 EVO: Hoses, cables and con- nectors .....	146
11.11	P16 EVO AVC: Schläuche, Kabel und Anschlüsse   P16 EVO AVC: Hoses, cables and connectors .....	148

**12 Declaration of Conformity ..... 152**

# 1 About these instructions

## 1.1 Warning messages

The warnings used in these instructions warn you of injuries or damage to property.





Always read and observe these warnings!





This is a warning icon. It warns against dangers of injury. In order to avoid injuries or death observe the measures marked with a safety sign.

---

### WARNING LEVEL MEANING

	<b>DANGER</b>	Imminently hazardous situation that results in death or serious injuries if the safety measures are not observed.
	<b>WARNING</b>	Potentially hazardous situation that may result in death or serious injuries if the safety measures are not observed.
	<b>CAUTION</b>	Potentially hazardous situation that may result in slight injuries if the safety measures are not observed.
	<b>NOTE!</b>	Potentially hazardous situation that may result in material damage if the safety measures are not observed.

## 1.2 Further icons and displays

SYMBOL	MEANING
	Request for action in a sequence of actions: Action is required here.
1.	Request for action in a sequence of actions: Action is required here.
2.	
3.	
...	
	Single request for action: Action is required here.

## 1.3 Further applicable documents

The following documents apply together with these operating instructions:

- Instructions for orbital welding power supply

## 2 Information and safety instructions for the owner

### 2.1 Requirements for the owner-operator

**Workshop/outdoor/field use:** The owner is responsible for safety in the danger zone around the machine, and should allow only qualified personnel to enter the zone or operate the machine in the danger zone.

**Employee safety:** The operator has to observe the safety regulations described in this chapter as well as has to work safety-consciously and with all prescribed safety equipment.

The employer undertakes to give the employees clear notice of the dangers arising that are specified in the EMF directives and to evaluate the workplace correspondingly.

**Requirements for special EMF evaluations with regard to general activities, working materials and workplaces\*:**

TYPE OF WORKPLACE OR WORK EQUIP- MENT	EVALUATION REQUIRED FOR:		
	Employees without particular risk	Employees at particu- lar risk (with the exception of those with active implants)	Employees with active implants
	(1)	(2)	(3)
Arc welding, manual (in- cluding MIG (Metal Inert Gas), MAG (Metal Active Gas), TIG (Tungsten In- ert Gas) under obser- vance of tried-and-tested procedures and without physical contact to the line	No	No	Yes

\* To Directive 2013/35/EU



## 2.2 Using the machine

### 2.2.1 Proper use

The orbital weld head is intended solely for the following utilization:

- Utilization in combination with an Orbital welding power supply of the ORBIMAT, Mobile Welder and Smart Welder series.
- TIG welding of materials that are specified in these operating instructions (see chap. applications).
- Empty unpressurized tubes that are free of contaminations, explosive atmospheres or liquids.

Only protective gases that are classified for TIG welding in accordance with EN ISO 14175 may be used.

Proper use also includes the following points:

- Permanent supervision of the machine during operation. The operator must always be able to stop the process.
- Observing all safety and warning information in these operating instructions and the general safety information for enclosed orbital weld heads.
- Observing of the further applicable documents.
- Complying with all inspection and maintenance work.
- Use of the machine solely in its original state.
- Usage solely of original accessories as well as original spare parts and operating materials.
- Checking of all the safety-relevant items and functions before commissioning.
- Processing of those materials named in the operating instructions.
- Proper usage of all components involved in the welding processes as well as of all further factors that have an influence on the welding process.
- Solely commercial usage.

## 2.2.2 Machine constraints

- The workplace can be in the tube preparation, in plant construction or in the plant itself.
- The machine is operated by one person.
- A space of about 2 m for people to move around the machine must be provided.
- Work lighting: min. 300 Lux.
- Ambient conditions during operation:  
Ambient temperature:  $-10\text{ °C}$  to  $+40\text{ °C}$   
Relative humidity:  $< 90\%$  at  $+20\text{ °C}$ ,  $< 50\%$  at  $+40\text{ °C}$
- Ambient conditions during storage and transport:  
Ambient temperature:  $-20\text{ °C}$  to  $+55\text{ °C}$   
Relative humidity:  $< 90\%$  at  $+20\text{ °C}$ ,  $< 50\%$  at  $+40\text{ °C}$
- The machine may only be installed and operated in a dry environment according to IP 23 (not in fog, rain, thunderstorms, etc.). If appropriate, use a welding tent.
- Smoke, steam, oil vapors and grinding dust must be avoided.
- Avoid salty ambient air (sea air).

## 2.3 Environmental protection and disposal

### 2.3.1 Information regarding the Ecodesign Directive 2009/125/EG



- Do not dispose of product (if applicable) with general waste.
- Reuse or recycle waste electrical and electronic equipment (WEEE) by disposing of it at a designated collection point.
- Contact your local recycling office or dealer for more information.

(as per RL 2012/19/EU)

**Critical raw materials potentially present in indicative quantities greater than 1 gram at the component**

COMPONENT	CRITICAL RAW MATERIAL
Printed circuit boards	Barite, bismuth, cobalt, gallium, germanium, hafnium, indium, heavy rare earths, light rare earths, Niobium, platinum group metals, scandium, silicon metal, tantalum, vanadium
Plastic components	Antimony, Barite
Electrical and electronic components	Antimony, beryllium, magnesium
Metal components	Beryllium, cobalt, magnesium, tungsten, vanadium
Cable and cable assemblies	Borate, antimony, barite, beryllium, magnesium
Displays	Gallium, indium, heavy rare earths, light rare earths, niobium, platinum group metals, scandium
Batteries	Fluorspar, heavy rare earths, light rare earths, magnesium

## 2.4 Personnel qualification

 **CAUTION!** The weld head/manual welding torch may only be used by instructed personnel.

- Only employ personnel who satisfy the job- and age-specific regulations that apply to the operation site.
- **No** physical and mental impairments.
- Persons whose ability to respond is affected by drugs, alcohol or medications are not eligible as staff.
- Operation of the machine by underage persons only under supervision by a person authorized to issue instructions.
- A basic knowledge of the TIG welding process is advisable.

## 2.5 Fundamental information on operational safety

 **CAUTION!** Observe valid safety and accident prevention regulations!

Improper usage can impair safety. This can result in life-threatening injuries.

- Never leave the weld head unattended when the power supply is switched on.
  - The operator must ensure that no 2nd person is located within the danger zone.
  - Do **not** modify or convert the weld head.
  - Use the weld head only in technically flawless operating order and condition.
  - Use only genuine tools, spare parts and accessories as well as specified operating materials.
  - In case of changes in the operating behavior, stop operation immediately and have the fault eliminated.
  - Do not remove safety devices.
  - Do not pull the machine by the hose package or the cable.
  - Repair and maintenance work on the electrical equipment may only be carried out by a qualified expert.
  - Opening or altering the weld head is prohibited, except for the purpose of removing foreign matter from the transmission.
- Observe the troubleshooting information (*see chapt. "Troubleshooting"* of the operating instructions).

**CAUTION!**

Risk of injury due to monotonous work and exhausting work in places that are difficult to access and performing overhead work!

Discomfort, tiredness and malfunctions in the motor system, restricted ability to react and cramping.

- 
- ▶ Increase break times.
  - ▶ Perform "loosening-up" exercises.
  - ▶ Assume an upright, fatigue-free and comfortable body position during operation.
  - ▶ Ensure a varied range of activities.
- Perform "loosening-up" exercises.
  - Ensure a varied range of activities.
  - Assume an upright, fatigue-free and comfortable body position during operation.

## 2.6 Personal protective equipment

The following personal protective equipment must be worn while working at the system:

- ▶ Safety gloves according to EN 407 for welding operation and DIN 388 for installing the electrode.
- ▶ Safety shoes according to EN ISO 20345, Class SB.
- ▶ For overhead work safety helmet according to EN 397.
- ▶ Wear hearing protection in work environments > 80 db (A).

## 2.7 Remaining risks

### 2.7.1

### 2.7.2 Electric shock

Two electrical potentials are applied during the welding process:

- Potential 1: Electrode/torch body (-)
- Potential 2: Remaining components of the weld head incl. pipe (+)



#### **DANGER!**

There is the risk of a fatal electric shock on simultaneous contact with both potentials during the high-frequency ignition.

---

- ▶ Before connecting the weld head and before mounting the electrode: Switch off orbital welding system.
- ▶ Before moving the rotor with closed weld heads, fit clamping cassette or clamping units and close clamping unit and flip cover.
- ▶ From the start of the welding process avoid contact with the tube and the housing of the orbital weld head.
- ▶ Wear safety gloves DIN 12477, Type A for welding operation and DIN 388, Class 4 for mounting the electrode.
- ▶ From the start of the welding process avoid contact with the tube and the housing of the orbital weld head.
- ▶ Wear safety gloves DIN 12477, Type A for welding operation and DIN 388, Class 4 for mounting the electrode.



#### **DANGER!**

Risk of death for people with heart problems or cardiac pacemakers.

---

- ▶ From the start of the welding process avoid contact with the tube and the housing of the weld head.

- ▶ Switch off the power supply when connecting or disconnecting a weld head or manual welding torch.
- ▶ If the weld head or manual welding torch is not ready for operation, switch it to the "Test" function.

**DANGER!**

Electrical hazards through touching as well as incorrect or damp protective equipment.

- ▶ Wear dry safety shoes, dry metal-free (grommet-free) leather gloves and dry safety suits to minimize the electrical hazard.
- ▶ Work on a dry surface.

**DANGER!**

Electric shock along with injuries and damage to property on other devices due to erroneous ignition with unmounted or incorrectly positioned weld head!

- ▶ Do **not** play with weld head.

**DANGER!**

Electric shock and risk of crushing due to improper action and opening of the weld head.

- ▶ Unplug the weld head from the power source.
- ▶ Allow machine to cool down sufficiently before opening.
- ▶ Allow only a professional electrician to access the electrical system.
- ▶ **Never** connect open weld head to the power source.

**WARNING!**

Various injuries and damage to property due to electromagnetic incompatibility of surrounding devices during high-frequency ignition and devices in operation without a protective ground.

- ▶ Use only electrical devices with protective insulation in the working area of the welding system.
- ▶ Observe electromagnetically-sensitive devices when igniting the system.

### 2.7.3 Dangers through electromagnetic fields

**DANGER!**

Depending on the form of the workplace, life-threatening electromagnetic fields can arise in the direct vicinity.

- ▶ People with heart problems or cardiac pacemakers must not operate the welding system.
- ▶ The owner has to ensure safe design of the workplace in accordance with the EMF Directive 2013/35/EU.
- ▶ Use only electrical devices with protective insulation in the working area of the welding system.

- ▶ Observe electromagnetically-sensitive devices when igniting the system.



## 2.7.4

### 2.7.5 Damage to eyes through radiation



**WARNING!** During the welding process infrared, glaring and ultraviolet rays arise that can seriously damage the eyes.

- ▶ **Do not** look into the electric arc.
- ▶ Wear eye protection to EN 170.
- ▶ **Do not** look into the electric arc.
- ▶ Wear eye protection to EN 170.

### 2.7.6 Risk of suffocation from an excessive amount of argon in the air



**DANGER!** When leaks in the gas supply occur, there is a danger of suffocation due to the high argon content in the ambient air. Irreversible damage or deadly hazard due to suffocation may be the result.

- ▶ Replace defective parts immediately and check daily for proper functioning.
- ▶ Check machine daily for externally visible damage and defects and have them remedied by a professional if necessary.
- ▶ Keep the lines and hoses away from heat, oil, sharp edges or moving device parts.
- ▶ Use only in well ventilated areas.
- ▶ Monitor oxygen, if necessary.

### 2.7.7 Poisonous vapors and substances



**WARNING!** Poisonous vapors and substances during the welding process and handling of the electrodes!

- ▶ Use extraction devices in accordance with the professional association's regulations (e.g. BGI: 7006-1).
- ▶ If necessary, monitor the oxygen level in the air.
- ▶ Extra caution is required with chrome, nickel and manganese.
- ▶ **Do not** use electrodes containing thorium.

## 2.7.8 Tripping over wires and cables

**CAUTION!** If the power cable, gas line or control cable are under tension, there is the danger that persons may trip over them and be injured.

**WARNING!** Tripping over the above could cause the weld current connection to be pulled out so that in the worst case an arc may arise between the weld current connection and the orbital weld system. Burns and glaring light may be the result.

- ▶ Ensure that under **no** circumstances can people trip over lines and/or cables.
- ▶ Do **not** put lines or cables under tension.
- ▶ Place the welding tongs in the transport case after dismantling.
- ▶ Ensure that the hose assembly is connected properly and that the strain relief is attached.

## 2.7.9 Long-lasting physical damage through wrong posture



**CAUTION!** Long-lasting physical damage due to incorrect posture. Risk of discomfort, tiredness and malfunctions in the motor system, restricted ability to react and cramping.

- ▶ Increase break times.
- ▶ Perform "loosening-up" exercises.
- ▶ Assume an upright, fatigue-free and comfortable body position during operation.
- ▶ Ensure a varied range of activities.

## 2.7.10 Injury through high weight

A significant health hazard exists during lifting. Observe machine weights, chapt. Gross weight!

Danger of impact and crushing exists in the following situations:

**CAUTION!** Falling of the orbital weld head during transportation, mounting/dismantling or setting up.



**CAUTION!** Falling of the transport case caused by it being put down improperly!

- ▶ Place the transport case on a stable base near (approx. 1.5 m) the welding power supply.



**CAUTION!** Falling of the weld head in case of impermissible usage in overhead position!

- ▶ Wear safety shoes to EN ISO 20345, Class SB.
- ▶ Place the transport case on a stable base near (approx. 1.5 m/ 4.9 ft) the welding power supply.

- ▶ Do **not** carry the transport case on a ladder.
- ▶ To set up the weld head place it flat and ensure that it cannot fall down.
- ▶ Fit drop guard to weld head.
- ▶ Weld head may **only be used with drop guard** in overhead positions.
- ▶ Do not transport the device by crane. Use handles, straps or holders for hand transport only.
- ▶ Always carry out orbital weld head OW 170 mounting/dismantling work on the pipe employing 2 persons.
  
- ▶ Wear safety shoes to EN ISO 20345, Class SB.
- ▶ Place the transport case on a stable base near (approx. 1.5 m/ 4.9 ft) the welding power supply.
- ▶ Do **not** carry the transport case on a ladder.
- ▶ To set up the weld head place it flat and ensure that it cannot fall down.
- ▶ Fit drop guard to weld head.
- ▶ Weld head may **only be used with drop guard** in overhead positions.
- ▶ Do not transport the device by crane. Use handles, straps or holders for hand transport only.
- ▶ Always carry out orbital weld head OW 170 mounting/dismantling work on the pipe employing 2 persons.

## 2.7.11 Burns and risk of fire

---

**CAUTION!** After welding the weld head and the workpiece are hot. Very high temperatures arise in particular after several consecutive welding processes. There is a danger of burns or damage to the points of contact when working on the weld head (for example, when changing clamps or mounting/removing the electrode). Materials without thermal resistance can be damaged when coming into contact with the hot weld head.

---

**WARNING!** Thermal problems can arise in the case of incorrect positioning of the weld head or the use of impermissible materials in the welding area. In the worst case a fire will be started. Observe the local general fire protection measures.

---

**WARNING!** Tripping over the above could cause the weld current connection to be pulled out so that an arc may arise between the weld current connection and the orbital weld system. This can result in burns and blindness, in the worst case a fire can be started.

- 
- ▶ Safety gloves in accordance with EN 407.
  - ▶ Wait until the surfaces have cooled down to below 50 °C (122 °F) before working on the weld head or before packing into the transport case.
  - ▶ Position the weld head correctly.
  - ▶ Use only permissible materials in the welding area.

- ▶ Let the cleaning agent evaporate completely after cleaning the weld head and prior to welding.
- ▶ Ensure that under **no** circumstances can people trip over lines and/or cables.
- ▶ Do **not** put lines or cables under tension.
- ▶ Place the weld head in the transport case after dismantling.
- ▶ Ensure that the hose package is connected properly and that the strain relief is attached.

## 2.7.12

### 2.7.13 Prick injury through pointed electrode and, if appropriate, cold wire



#### CAUTION!

Falling of the orbital weld head during transportation, mounting/dismantling or setting up.

### 2.7.14 Danger of crushing through being caught in by moving parts



#### CAUTION!

Hands and fingers can be caught in and crushed while setting up the weld head.

- ▶ Before setting up or before electrode replacement lay the weld head flat on the base
- ▶ Switch off the welding power supply before setting up or before an electrode replacement.



#### CAUTION!

Risk of body parts being crushed due to the clamping cassette falling off when clamping onto the workpiece.

- ▶ Attach drop guard to the clamping cassette (OW 25 GC only).
- ▶ Make sure that no one is beneath the site of operation.
- ▶ Wear personal protective equipment.

### 2.7.15 Injury through rotating machine parts

#### DANGER!

The rotating machine parts can cause hair, jewelry or clothes to be caught and pulled into the housing.

#### CAUTION!

Risk of crushing of hands and fingers!

The rotor can start up unexpectedly during the setup of the electrode.

- ▶ Before connecting the weld head and before mounting the electrode: Switch off orbital welding system.

- ▶ Before moving the rotor with closed weld heads, fit clamping cassette or clamping unit and close flip cover.
- ▶ Wear tight-fitting clothes.
- ▶ **Do not** wear open hair, jewelry or other accessories that can be easily drawn in.

## 2.7.16 Danger of cuts at sharp edges

---

**CAUTION!** Danger of cut injuries caused by sharp tube edges when clamping the weld head at the tube.

---

- ▶ Wear safety gloves according to DIN 388.

## 2.7.17 Risk of injury and fire due to defective components

---

**DANGER!** Safety parts can fail due to impurity, breakage and wear, causing many risks of injury and risk of fire and burning due to the arc.

---

- ▶ Do not misuse the cable, for example by suspending or carrying the machine by the cable.
- ▶ Replace defective parts immediately and check daily for proper functioning.
- ▶ Have an expert replace defective lines and plugs immediately.
- ▶ Clean and maintain machine after every use.
- ▶ Keep the lines and hoses away from heat, oil, sharp edges or moving device parts.
- ▶ Check machine daily for externally visible damage and defects and have them remedied by a professional if necessary.

## 2.7.18 Danger from incorrect handling of system components



---

**DANGER!** Many injuries and material damage due to incorrect use of pressure tanks and other parts of the system (e.g. welding gas cylinder)!

---

- ▶ Heed safety regulations, especially those for pressure tanks.
- ▶ Comply with safety data sheets.
- ▶ If the system and its components exceed 25 kg in weight, lift using several people or lifting equipment.
- ▶ Heed safety regulations, especially those for pressure tanks.
- ▶ Comply with safety data sheets.
- ▶ If the system and its components exceed 25 kg in weight, lift using several people or lifting equipment.

## 2.7.19 General injuries through tools

---

**CAUTION!**

Injuries can occur during dismantling for the proper disposal of the weld head through uncertainties in handling tools.

---

- ▶ In case of uncertainties send the weld head to Orbitalum Tools – proper disposal is carried out here.
- ▶ Allow only a professional electrician to access the electrical system and open the weld head.

## 2.7.20

## 2.7.21

## 2.7.22

### 3 Description

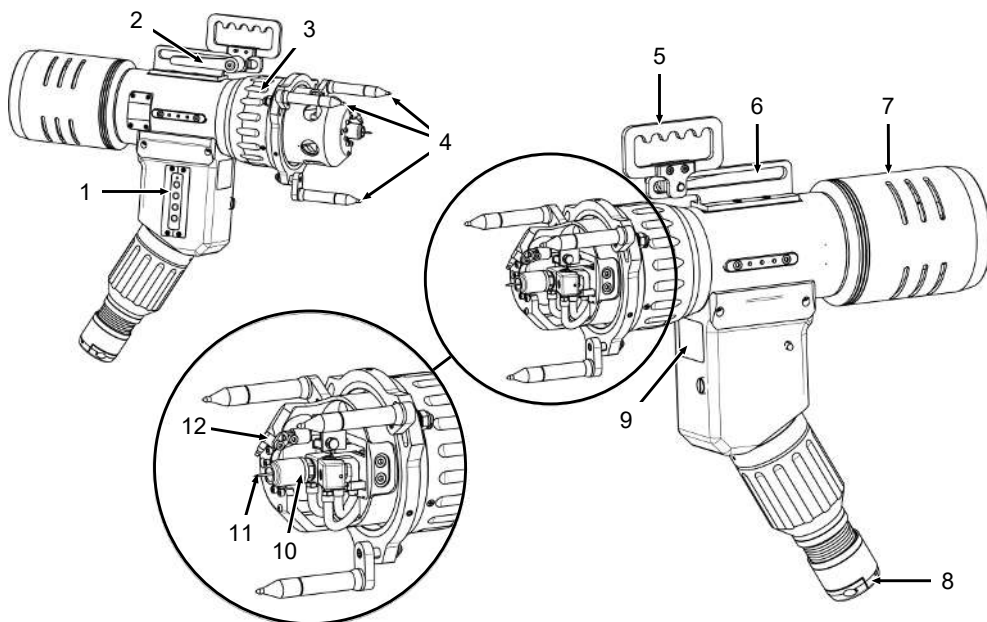

NO.	DESIGNATION	FUNCTION
1	Control panel	Operate weld head.
2	Adjustable clamping lever	Clamp and release balance eye to bracket
3	Adjusting flange	To adjust the distance between weld head and pipe sheet during welding of protruding pipes.
4	3-point support	Spacer between weld head and pipe sheet during welding of protruding pipes.
5	Balance eye	Hand the weld head balanced.
6	Bracket	Bears the balance eye and allows for it to be horizontally aligned.

NO.	DESIGNATION	FUNCTION
7	Cold wire feed	Bears the cold wire roller and conveys the cold wire to the wire nozzle.
8	Hose assembly connection socket	Connect weld head with welding power supply.
9	Type plate	Bears model designation, serial and specification number, year of construction and motor type.
10	Torch	Bears the electrode for creating the arc.
11	Tungsten electrode	Focuses the arc.
12	Cold wire adjustment unit	Align cold wire nozzle.



## 4 Application area

APPLICATION AREA	P16 EVO	P16 EVO KD	P16 EVO AVC KD	REMARK
Code	831 000 003	831 000 001	831 000 002	
From pipe ID to pipe OD	[mm] 10,0 ... 78,0*		20,0 ... 100,0**	
	[inch] 0.394 ... 3.071*		0.787 ... 4.016**	
From pipe ID to pipe ID	[mm] 12.0 ... 78.0			Pipe axis parallel to electrode (standard)
	[inch] 0,472 ... 3.071			
	[mm] 10.0 ... 36.0			Pipe axis inclined 30° to electrode.
	[inch] 0,394 ... 1.417			Greater diameter upon request.
Welding process	Tungsten inert gas process (TIG)			
Materials	All materials that are fundamentally suitable for the TIG welding process.			
* Expandable OD 20 mm - OD 126,00 mm (0.787 - 4,016 in)				
** Expandable OD 10 – OD 140mm (0.394 - 5.512 in)				

### NOTICE!



**The inner diameter of the pipe is definitive for the selection of the correct centering cartridge.**

► Ensure matching centering cartridge/arbor combination.

### Centering unit for outside welding

The centering unit guarantees that the machine turns in parallel to the pipe axis during welding.

There is a spindle available for this that is fitted with 5 bolts on the cover mounted before the torch.

The centering cartridges are slid on and engaged with this spindle.

The centering cartridge is particularly effect as, thanks to elastic fitted balls, it allows the weld head also to be used on slightly oval or deformed pipes.

Spindles and centering cartridges must, depending on the inner diameter of the pipe, be selected from the following table.

ITEM	GROUP	CARTRIDGE SIZE/ NO.	PIPE ID [MM]	PIPE ID [INCH]	CODE	KG
<b>Arbor for centering cartridge for group A</b>					832 020 003	0.060
Centering cartridge	A	1	10.0 - 10.5	0.394 - 0.413	832 020 004	0.040
Centering cartridge	A	2	10.5 - 11.0	0.413 - 0.433	832 020 005	0.050
Centering cartridge	A	3	11.0 - 11.5	0.433 - 0.452	832 020 006	0.070
Centering cartridge	A	4	11.5 - 12.0	0.452 - 0.472	832 020 007	0.070
Centering cartridge	A	5	12.0 - 12.5	0.472 - 0.492	832 020 008	0.080
Centering cartridge	A	6	12.5 - 13.0	0.492 - 0.512	832 020 009	0.100
Centering cartridge	A	7	12.8 - 14.0	0.504 - 0.551	832 020 011	0.110
<b>Arbor for centering cartridge for group B</b>					832 020 010	0.070
Centering cartridge	B	8	13.8 - 15.0	0.543 - 0.591	832 020 012	0.120
Centering cartridge	B	9	14.8 - 16.0	0.583 - 0.630	832 020 013	0.140
Centering cartridge	B	10	15.8 - 17.0	0.622 - 0.669	832 020 014	0.150
Centering cartridge	B	11	16.8 - 18.0	0.661 - 0.709	832 020 015	0.180
Centering cartridge	B	12	17.8 - 19.0	0.701 - 0.748	832 020 016	0.190
Centering cartridge	B	13	18.8 - 20.0	0.740 - 0.787	832 020 017	0.200
Centering cartridge	B	14	19.8 - 22.5	0.780 - 0.886	832 020 018	0.250
<b>Arbor for centering cartridge for group C</b>					832 020 019	0.115
Centering cartridge	C	15	22.3 - 25.0	0.878 - 0.984	832 020 020	0.340
Centering cartridge	C	16	24.5 - 27.0	0.965 - 1.063	832 020 021	0.350

ITEM	GROUP	CARTRIDGE SIZE/ NO.	PIPE ID [MM]	PIPE ID [INCH]	CODE	KG
Centering cartridge	C	17	26.5 - 29.0	1.043 - 1.142	832 020 022	0.360
Centering cartridge	C	18	28.5 - 31.0	1.122 - 1.220	832 020 023	0.400
Centering cartridge	C	19	30.5 - 33.0	1.201 - 1.299	832 020 024	0.500
Centering cartridge	C	20	32.5 - 36.0	1.280 - 1.417	832 020 025	0.510
Centering cartridge	C	21	33.5 - 39.0	1.319 - 1.535	832 020 026	0.530
Centering cartridge	C	22	38.5 - 42.0	1.516 - 1.654	832 020 027	0.550
Centering cartridge	C	23	41.5 - 45.0	1.634 - 1.772	832 020 028	0.560
Centering cartridge	C	24	44.5 - 48.0	1.752 - 1.890	832 020 029	1.000
Centering cartridge	C	25	47.5 - 51.0	1.870 - 2.008	832 020 030	1.200
<b>Arbor for centering cartridge for group D</b>					832 020 031	0.215
Centering cartridge	D	26	50.5 - 54.0	1.988 - 2.126	832 020 032	1.500
Centering cartridge	D	27	53.5 - 58.0	2.106 - 2.283	832 020 033	1.800
Centering cartridge	D	28	57.5 - 62.0	2.264 - 2.441	832 020 034	1.900
Centering cartridge	D	29	61.5 - 66.0	2.421 - 2.598	832 020 035	2.100
Centering cartridge	D	30	65.5 - 70.0	2.579 - 2.756	832 020 036	2.400
Centering cartridge	D	31	69.5 - 74.0	2.736 - 2.913	832 020 037	2.600
Centering cartridge	D	32	73.5 - 78.0	2.894 - 3.071	832 020 038	2.800
Centering cartridge	D	33	77.5 - 82.0	3.051 - 3.228	832 020 039	3.100

ITEM	GROUP	CARTRIDGE SIZE/ NO.	PIPE ID [MM]	PIPE ID [INCH]	CODE	KG
Centering cartridge	D	34	82.0 - 87.0	3.228 - 3.425	832 020 045	3.100
Centering cartridge	D	35	87.0 - 91.0	3.425 - 3.582	832 020 046	-
Centering cartridge	D	36	91.0 - 95.0	3.582 - 3.740	832 020 047	-
Centering cartridge	D	37	95.0 - 99.0	3.740 - 3.897	832 020 048	-
Centering cartridge	D	38	99.0 - 103.0	3.897 - 4.055	832 020 049	-
Centering cartridge	D	39	103.0 - 107.0	4.055 - 4.212	832 020 050	-
Centering cartridge	D	40	107.0 - 111.0	4.212 - 4.370	832 020 051	-
Centering cartridge	D	41	111.0 - 115.0	4.370 - 4.527	832 020 052	-
Centering cartridge	D	42	115.0 - 120.0	4.527 - 4.724	832 020 053	-

\* *Smaller and larger dimensions on request.*

See product catalog "Orbital Welding" for a comprehensive overview of suitable accessories.

Download link PDF: <https://www.orbitalum.com/de/download.html>



## 5 Technical specifications

MODEL		P16 EVO	P16 EVO KD	P16 EVO AVC KD
Code		833 000 003	833 000 001	833 000 002
Weight machine including hose assembly	[kg]	16.20	17.50	18.30
	[lbs]	35,715	38,581	40,345
Hose assembly weight	[kg]		5.50	
	[lbs]		12.125	
Hose assembly length	[m]		7.50	
	[ft]		24,600	
Torch cooling			Water	
Incline of torch max.	[°]		± 45	
Welding diameter with electrode parallel (standard) to pipe axis.	[mm ]		12 - 78	
			<b>NOTICE! Greater diameter upon request.</b>	
Welding diameter with electrode inclined 30° to pipe axis.	[mm ]		10 - 36	
			<b>NOTICE! Greater diameter upon request.</b>	
Weld current, max.	[A]		180 DC constant	
			200 DC pulse	
Rotation speed:	[rpm ]		0.33 - 6.00	
Front diameter of weld head (standard)	[mm ]	120		
Adjustable welding distance to torch holder	[mm ]	6		
Adjustable welding distance to front support of rotor plate	[mm ]	+/- 5		
		<b>NOTICE! Setting is micrometric!</b>		
Cold wire supply unit		-	<b>NOTICE! Can be removed if machine body is not used.</b>	
Cold wire speed	[m/min]	-	0.15 - 1.50	
Cold wire coil weight (standard)	[kg]	-	1	

MODEL	P16 EVO	P16 EVO KD	P16 EVO AVC KD
Cold wire coil diameter (standard) [mm ]			100
Cold wire diameter (split rolls series 1) [mm ]	-		0.6 - 0.9
Supplementary wire diameter (split rolls series 2) [mm ]	-		0.9 - 1.2
		Normally the machine is delivered with split roll series 1 as standard.	

## 5.1

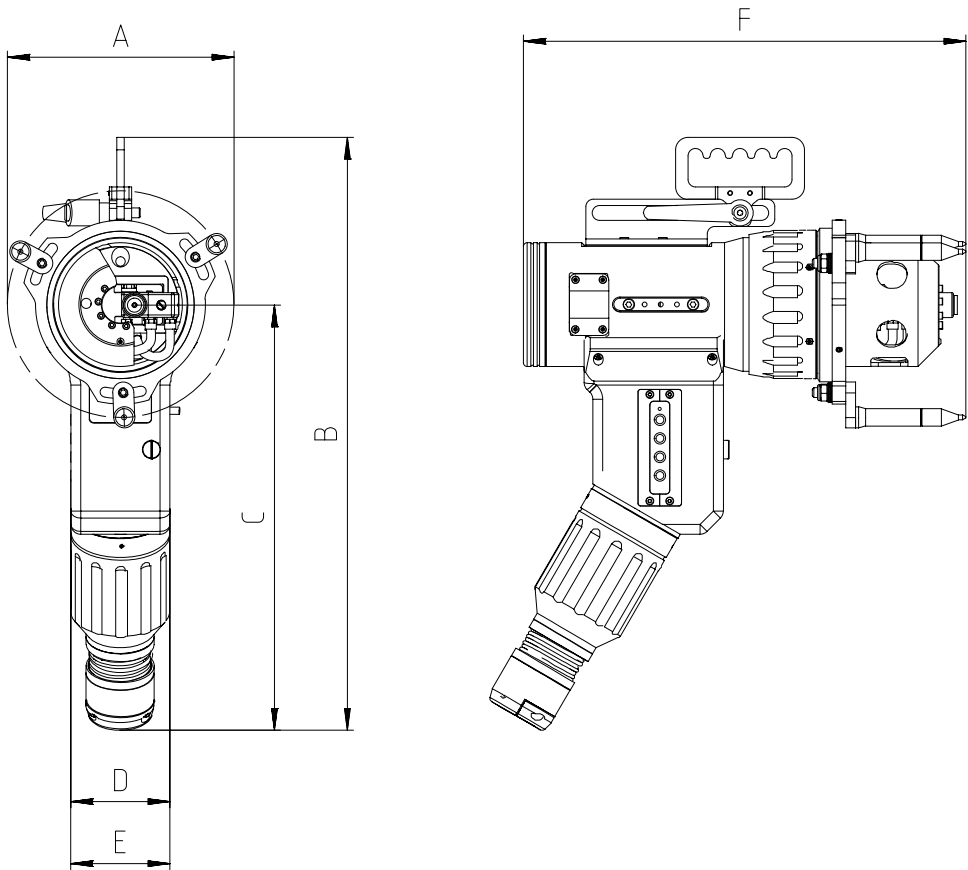

Illustration: P16 EVO without cold wire

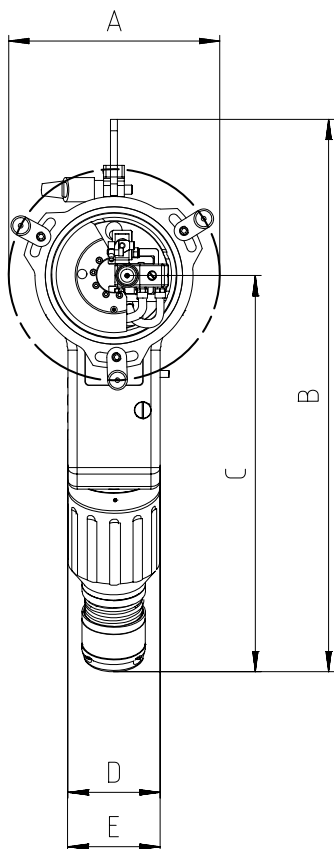
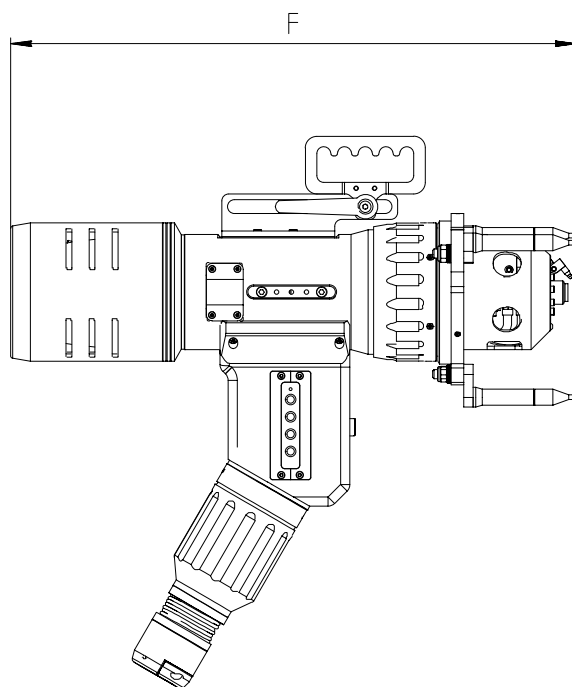

Illustration: P16 EVO with cold wire





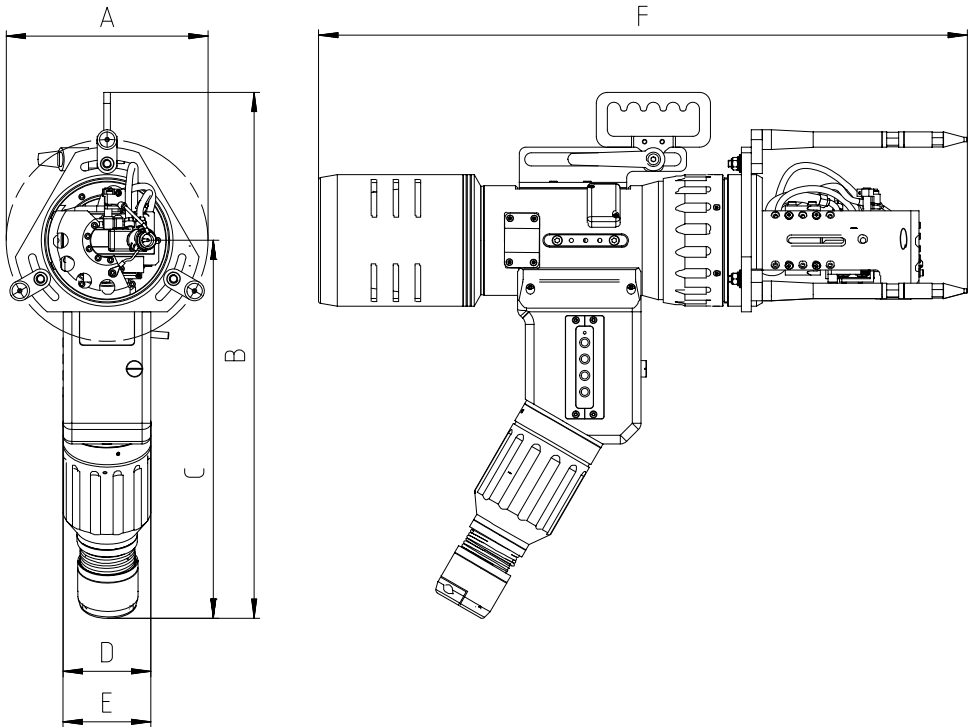

Illustration: P16 EVO AVC with cold wire

TYPE		P16 EVO	P16 EVO KD	P16 EVO AVC KD
Code		833 000 003	833 000 001	833 000 002
Dimension "A":	[mm]	183.00	183.00	184.00
	[inch]	7,204	7,204	7,244
Dimension "B"	[mm]	478.84	478.84	478.84
	[inch]	19,202	19,202	19,202
Dimension "C":	[mm]	343.40	343.40	344.74
	[inch]	13,504	13,504	13,572
Dimension "D"	[mm]	80.00	80.00	80.00
	[inch]	3,150	3,150	3,150
Dimension "E":	[mm]	80.20	80.20	80.20
	[inch]	3,157	3,157	3,157
Dimension "F"	[mm]	357.31	489.81	591.50
	[inch]	14,067	19,284	23.,287

## 6 Transport and shipping

### INFO



The following illustrations for the individual work steps show the weld head model P 16 EVO AVC as an example. Procedures or work steps that deviate are, if required, described separately and represented in a separate figure.

### 6.1 Gross weight

MODEL		P16 EVO	P16 EVO KD	P16 EVO AVC KD
Weight*	[kg]	27.20	28.50	29.30
	[lbs]	59.97	62.83	64.60

\* incl. scope of delivery and transport case

### 6.2 Transport

#### CAUTION



**Danger of injury through high weight of the weld head!**  
The weld head with hose package has a weight of 19.30 kg (42.55 lbs).

- ▶ Lift the orbital weld head carefully.
- ▶ Place the transport case on a secure base.
- ▶ Wear safety shoes to EN ISO 20345, Class SB.

#### CAUTION



**Danger of injury through pointed electrode!**

If the weld head is removed incorrectly from the transport case, there is the danger that you may touch the pointed electrode.

- ▶ Use the handle and balance eye provided to remove the weld head.
- ▶ Dismantle the electrode before transport.

- ▶ Carry transport case by handle.



- ▶ Use the handle (1) and balance eye (2) to remove the weld head from the transport case.

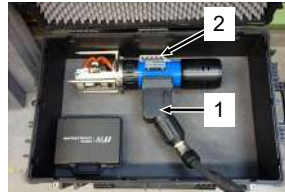

## 7 Commissioning

### 7.1 Scope of delivery

ITEM	CODE	QUANTITY	UNIT
P16 EVO/	833 000 003/	1	PCS.
P16 EVO with cold wire/	833 000 001/		
P16 EVO AVC with cold wire	833 000 002		
Tool set P16 (AVC)	831 001 164	1	PCS.
General safety instructions, P16 EVO	833 060 101	1	PCS.
Operating instructions & ETL, P16 EVO	831 060 201	Unlimited (PDF)	PCS.
Download link PDF:			
<a href="https://www.orbitalum.com/de/download.html">https://www.orbitalum.com/de/download.html</a>			
			
Transport case EX 70	814 030 001	1	PCS.

*We reserve the right to make changes.*

- ▶ Check the delivery for completeness and damage caused by transport.
- ▶ Report any missing parts or damage caused by transport to your supplier immediately.

## 7.2 Preparing initial operation

### WARNING



#### Risk of explosion when using incorrect (explosive) gases during welding process.

Severe injuries and death may be the result.

- ▶ Observe safety instructions in the operating instructions of the power supply.
- ▶ Usage solely of protective gases that are classified for TIG welding process in accordance with EN ISO 14175.

### WARNING



#### Risk of burns, blindness and fire due to arcs!

An arc may develop by releasing the welding contacts during operation. This can result in burns and blindness, in the worst case a fire can be started.

- ▶ Connect and disconnect the weld head only when the power supply is shut down.
- ▶ Lay the lines and cables so that they are **not** under tension.
- ▶ Ensure that under **no** circumstances can people trip over lines and/or cables.
- ▶ Attach the strain relief.
- ▶ Check that hose package connections fit firmly in place when connecting or before activating the power supply.
- ▶ Do not work near highly flammable substances.

- ✓ Welding power supply connected to power grid and ready to operate.
- ▶ Check the weld head, hose package, ground cable and lines for damage.
- ▶ Check the working environment for possible sources of danger and, if applicable, eliminate these.
- ▶ Fill weld head with cooling liquid (see the chapter Carry out the gas and cooling-liquid function test).
- ▶ Check the weld head for loose parts and particles in the transmission.

## 8 Set-up and mounting

### 8.1 Procedure

---

**NOTICE!**

**Observe operating instructions of the ORBIMAT welding power supply or Mobile Welder!**

---

1. If necessary Fit cold wire conveyor unit (optional) [▶ 39]
2. Hang the weld head on the spring balancer [▶ 44]
3. Connecting the weld head to the power source [▶ 45]
4. Set up/replace the electrode [▶ 49]
5. Fit centering unit [▶ 53]
6. Clamp the weld head in the workpiece [▶ 54]
7. Adjust welding diameter [▶ 55]
8. Adjust welding gap [▶ 58]
9. If necessary Position wire nozzle [▶ 59]
10. Carry out the gas and cooling-liquid function test [▶ 61]
11. Configure welding procedure (*see operating instructions of the welding power source*)

## 8.2 Fit cold wire conveyor unit (optional)

1. Fasten front wire nozzle holder. (see chap. Replace wire guide nozzle [► 71]).
2. Unscrew end cap (1) from weld head body (4).

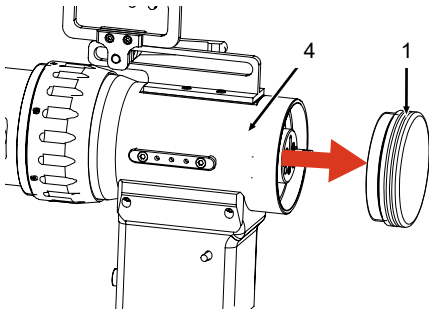

3. Position the cold wire conveyor unit (2) on the weld head body (4) and slide the front wire guide hose (3) into the wire guide channel (5).

**NOTICE! Make sure that the sliding knuckle (6) is in the correct position!**

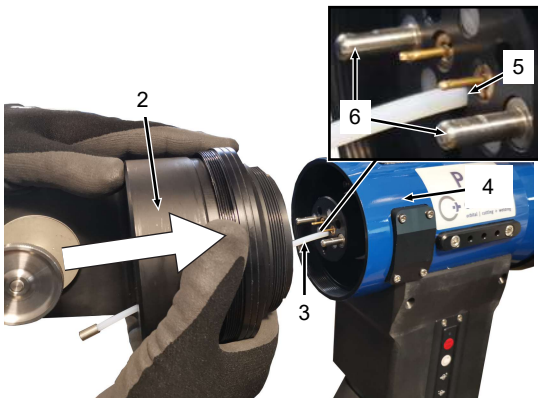

4. Screw cold wire conveyor unit (2) onto weld head body (4).
5. Screw the wire guide nozzle onto the end of the front wire guide hose and fit to the holder (see chap. Replace wire guide nozzle [► 71]).
6. Fit wire coil (see chap. Insert wire coil and set wire feed rolls pressure [► 41]).

► **To remove** the cold wire conveyor unit carry out the work steps in the reverse order.

## 8.2.1 Replace wire coil

### 8.2.1.1 Remove wire coil

- ▶ Unscrew protective cover (1) and safely set aside.

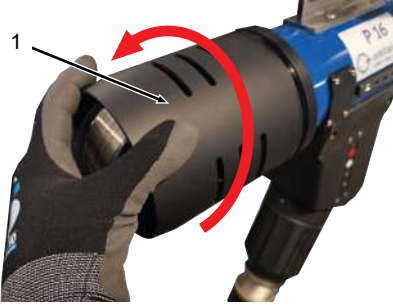

- ▶ Cut through wire (2) between coil and wire guide hose with a cutter.

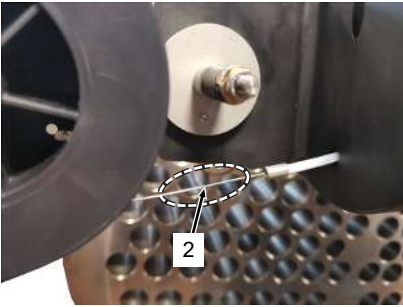

- ▶ Activate wire feed: Press "MANUAL WIRE FEED" button and hold it until it automatically stops (see *chap. Manual wire feed and retraction* [▶ 64]).

OR via welding power supply:

- ▶ See *operating instructions of the welding power source*.



- ▶ Pull wire (3) out of the wire guide nozzle with pliers.

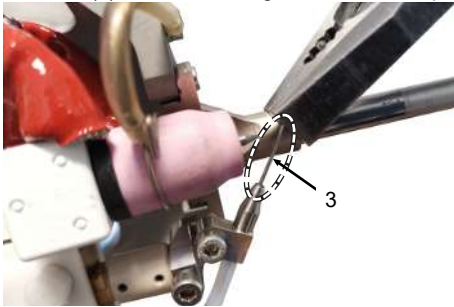

- ▶ Unscrew knurled nut (4) and remove the old coil.

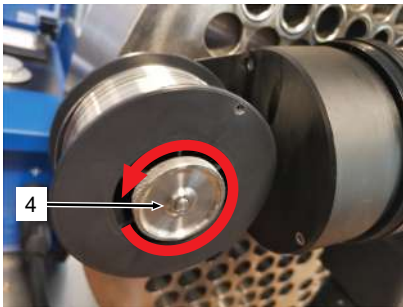

### 8.2.1.2 Insert wire coil and set wire feed rolls pressure

The supplementary wire is conveyed between two conveyor rolls that press against one another through the guide hose. The roll pressure can be regulated via an adjusting screw.

- If the conveyor rolls of the supplementary wire supply are too far apart, the wire cannot be caught by it.
- If the conveyor rolls are too close, the wire stops before it.

In both cases it is necessary to correct the pressure of the rolls using the adjusting screw.

#### **NOTICE!**



#### **The correct roll pressure is very important!**

Too weak pressure can cause stoppages, i.e. brief interruption of wire supply, therefore faulty seam.

Too strong roll pressure unnecessarily strains the entire supply group.

In order to set the pressure of the wire feed rolls, proceed as follows:

1. Unscrew wire nozzle from the holder so that the wire guide hose can be held without bending. See *the chapter* Replace wire guide nozzle [▶ 71]
2. Switch on the welding power supply (*see operation manual of welding power supply*).

3. Round off/deburr wire end of the new wire roll with a metal file.
  4. Insert wire end into the rear guide hose (3) and carefully keep pushing until resistance of the conveyor rolls.
- If the wire gets caught before the closed conveyor rolls, open adjusting screw (2) wide enough so that the wire can be pushed through to the weld head.

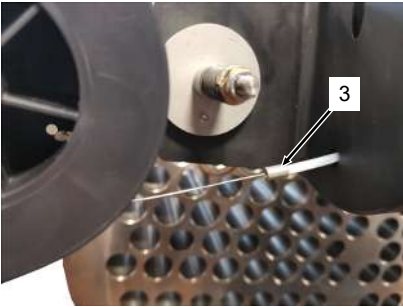

- ▶ Activate wire feed: Press "MANUAL WIRE FEED" button and hold it until it automatically stops (see chap. Manual wire feed and retraction [▶ 64]).

OR via welding power supply:

- ▶ See operating instructions of the welding power source.
- ▶ Meanwhile, tighten the adjusting screw (2) until the wire is pulled into the guide hose. Then tighten the adjusting screw another half rotation.
- ▶ Activate wire feed until the wire comes out of the wire guide nozzle.

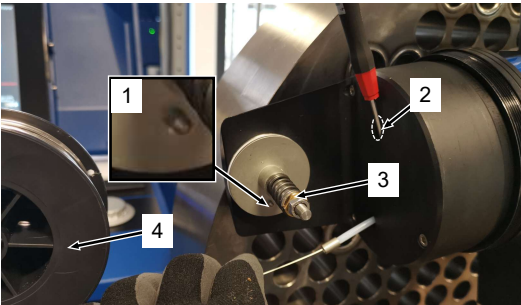

- ▶ Place the wire coil (4) on the shaft (3).

**NOTICE!**



**Make sure that the locking pin (1) of the outer brake disc is used in a designated hole in the coil.**

- ▶ Put a sufficiently large hole in position of the locking pin in the plastic coil.

- ▶ Screw knurled nut (5) to the thread of the shaft (3).

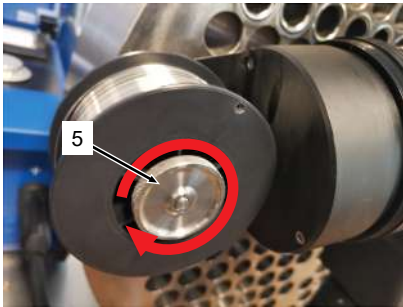

- ▶ Reinsert and tighten wire nozzle, *see chap.* Replace wire guide nozzle [▶ 71].
- ▶ Unscrew the protective cover (6).

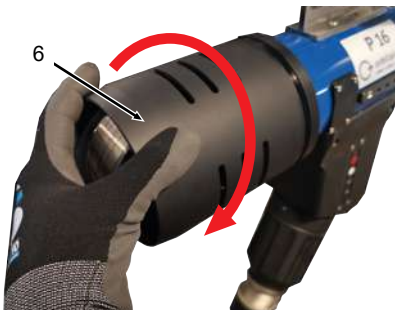

---

**NOTICE!**

The wire unit has a coupling that brakes the coil to stop the wire from uncoiling by itself.

---

- ▶ At the welding power supply set the desired wire feed speed, whereby in a simulated cycle the regularity of the feed can be checked.
- ▶ Then check the wire feed direction.

## 8.3 Hang the weld head on the spring balancer

For an optimum welding result and to relieve the centering unit, hang the weld head to a suspension rope with spring balancer.

### NOTICE!



With the installation of a holding rope of 2 m length at an angle of 10°-15° to the pipe sheet it is ensured that the weld head is pressed with the necessary force against the pipe sheet.

- ✓ Optional cold wire conveyor unit is fitted
  - ✓ Centering unit is **not** fitted to the weld head.
  - ✓ Spring balancer is fitted over the pipe sheet.
- ▶ Connect holding rope (5) with a suitable fastener such as a snap hook (4) with the balance eye (2) of the weld head.

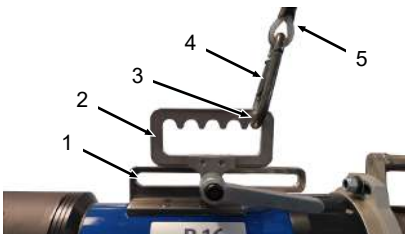

- ▶ Hold weld head horizontally before the pipe end to be welded and set the 3-point support on the pipe sheet.

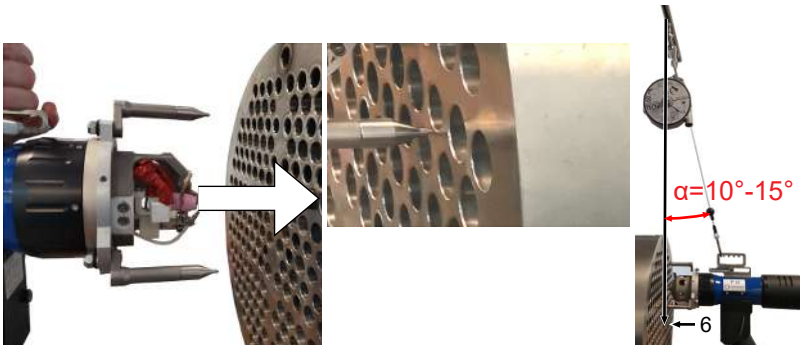

- ▶ Check whether the angle  $\alpha$  between the holding rope and pipe sheet is 10°-15° and, if necessary, adjust. The 5 snap-in positions (3) in the balance eye (2) can be used for this and the position of the balance eye itself can be changed on the bracket (1).

## 8.4 Connecting the weld head to the power source

- ✓ Optional cold wire conveyor unit is fitted. *See the chapter* Fit cold wire conveyor unit (optional) [▶ 39]
- ✓ Centering unit is **not** fitted to the weld head.
- ✓ Weld head is hung on the spring balancer. *See the chapter* Hang the weld head on the spring balancer [▶ 44]

### WARNING



#### Risk of burns, blindness and fire due to arcs!

An arc may develop by releasing the welding contacts during operation. This can result in burns and blindness, in the worst case a fire can be started.

- ▶ Connect and disconnect the weld head only when the power supply is shut down.
- ▶ Lay the lines and cables so that they are **not** under tension.
- ▶ Ensure that under **no** circumstances can people trip over lines and/or cables.
- ▶ Attach the strain relief.
- ▶ Check that hose package connections fit firmly in place when connecting or before activating the power supply.
- ▶ Do not work near highly flammable substances.

### CAUTION



#### Unintentional starting up of the weld head!

Crushing of hands and fingers.

- ▶ Switch off the Orbital welding power source.

### NOTICE!



#### Overheating of the weld head and damaging of the hose package because of a lack of cooling liquid!

- ▶ Ensure that the coolant tank of the welding power supply or of the external cooling device is filled sufficiently (coolant level should at least reach the "MIN" marking on the tank).

### NOTICE!



#### During initial commissioning:

**The hose package may be damaged while being unpacked from the packaging foil!**

- ▶ Carefully sever the cable ties without damaging the hose package.

## 8.4.1 Connection sequence

See *the chapter* Anschlusschema [► 47]

1. Attach the strain relief.
2. Connect the Amphenol plug.
3. Connect the welding current plug and welding current socket.
4. Connect the blue and red cooling liquid cable.
5. Connect the gas hose.
6. Switch on the welding power supply.
7. Carry out gas and cooling liquid function test. See *the chapter* Carry out the gas and cooling-liquid function test [► 61]

## 8.4.2 Anschlussschema

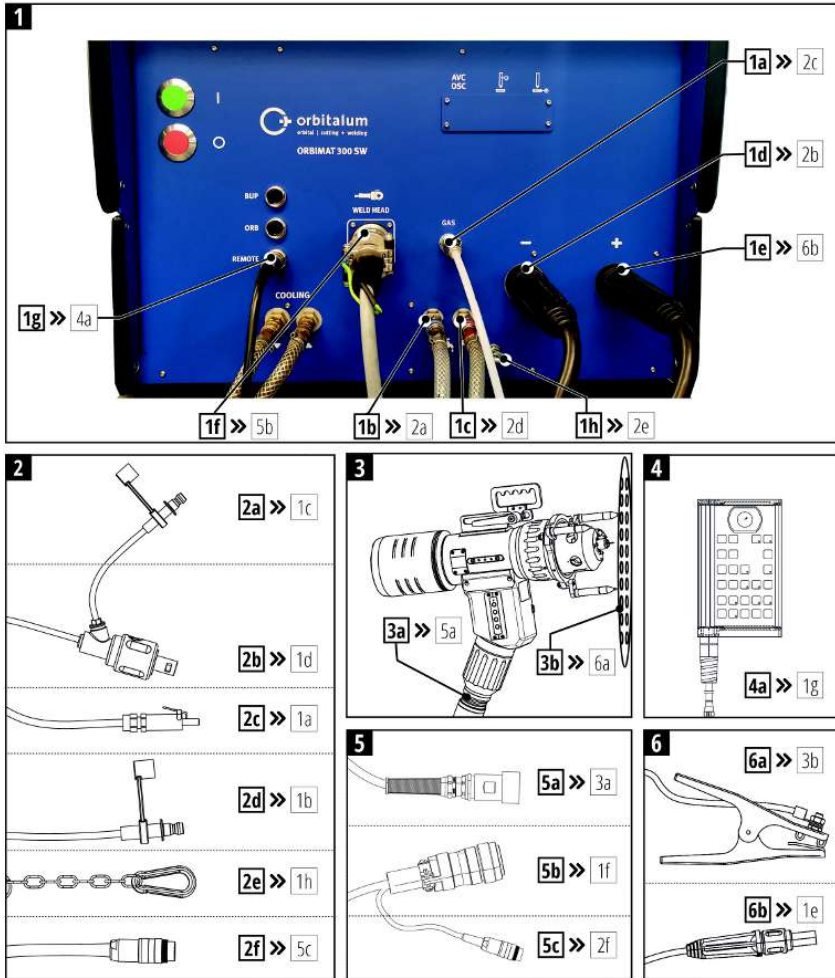

NO.	DESIGNATION	TO BE CONNECTED WITH	NO.
<b>1</b>	<b>Power source, e.g. Type ORBIMAT 300 SW</b>		
1a	Socket "Gas" (quick lock)	Plug "Gas", hose package	2c
1b	"Coolant supply line" socket, <b>blue</b>	"Coolant supply line" plug, <b>blue</b> , hose assembly	2a
1c	"Coolant return line" socket, <b>red</b>	"Coolant return line" plug, <b>red</b> , hose assembly	2d

NO.	DESIGNATION	TO BE CONNECTED WITH	NO.
1d	"Welding current –" socket (hose assembly)	"Welding current –" plug, hose assembly, if necessary, with connection adapter*	2b
1e	"Welding current +" plug (ground cable)	"Welding current +" socket, ground cable	6b
1f	Socket (Amphenol) "control line"	Plug (Amphenol) "control line to power source"	5b
1g	Socket "Remote control"/"Dummy plug"	Plug "Remote control" (optional) or "Dummy plug"	4a
1h	"Strain relief" eye	"Strain relief" snap hook, hose package	2e
<b>2 Hose package</b>			
2a	Plug "Coolant supply line", <b>blue</b>	Socket "Coolant supply line", <b>blue</b> , power source	1b
2b	"Welding current –" plug	"Welding current –" socket, power source, if necessary, with connection adapter*	1d
2c	"Gas" plug (quick lock)	"Gas" socket, power source	1a
2d	"Coolant return line" plug, <b>red</b>	"Coolant return line" socket, <b>red</b> , power source	1c
2e	"Strain relief" snap hook	"Strain relief" eye, power source	1h
2f	Plug "Cold wire"	Socket "Cold wire", control line	5c
<b>3 Weld head, e.g. P16 EVO model</b>			
3a	Socket "Control line"	Plug "Control line to welding tongs", control line	5a
3b	Hose	Clamp "Ground cable"	6a
4	Remote control, optional – not included in scope of delivery		
4a	Plug "Remote control"	Socket "Remote control"/"Dummy plug", power source	1g
<b>5 Control cable</b>			
5a	Plug "Control line to welding tongs"	Socket "Control line", welding tongs	3a
5b	Plug (Amphenol) "control line to power source"	Socket (Amphenol) "Control line" power source	1f
5c	Socket "Cold wire"	Plug "Cold wire", hose package	2f
<b>6 Ground cable</b>			
6a	Clamp "Ground cable"	Workpiece/hose	3b
6b	Socket "Ground cable"	"Welding current +" plug, power source	1e

\* For use with older Orbitalum welding power sources and heads with green Superior connections. Newer machine models are already equipped with DINSE-compatible connections.



## 8.5 Set up/replace the electrode

### CAUTION



#### Unintentional starting up of the weld head!

Crushing of hands and fingers.

- ▶ Switch off the Orbital welding power source.

### NOTICE!



Before inserting the electrode, check that it has the correct length and the sharpness. Rework, if necessary. See the chapter Grinding electrode

- ▶ Raise HF spiral (1) on handle (2) and pull from the gas nozzle (4).

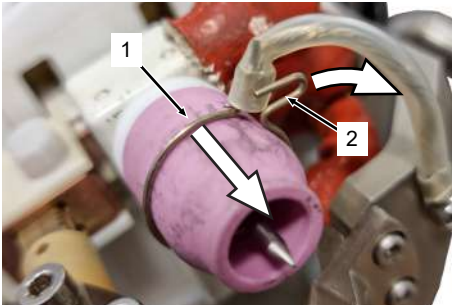

- ▶ Screw gas nozzle (3) counterclockwise from the gas lens (4).

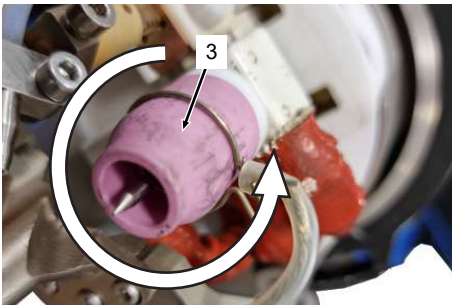

- ▶ Turn gas lens (4) counterclockwise from its thread and remove with the torch insulator (5).

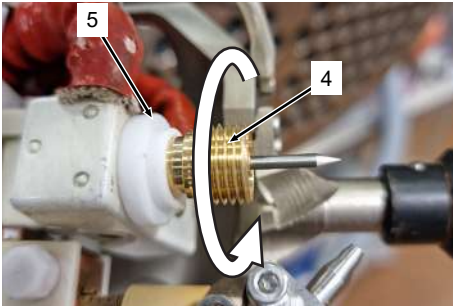

- ▶ Pull clamping sleeve (6) from gas lens (4).

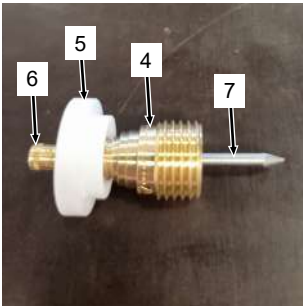

- ▶ Pull electrode (7) and clamping sleeve (6) or move to the desired position.

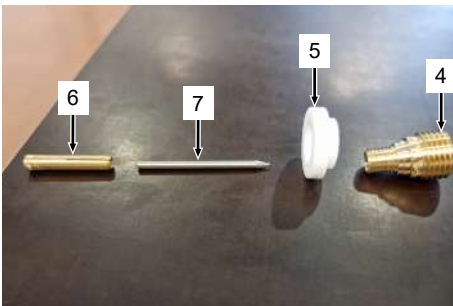

- ▶ In the event of an electrode replacement, push new electrode into gas lens and carry out work steps in reverse order.

## 8.5.1 Grinding electrode

### DANGER



**Electrical hazards due to touching as well as incorrect or damp protective equipment.**

Electric shock.

- ▶ Do **not** touch energized parts (pipe), especially when igniting the arc.
- ▶ Do **not** allow persons with increased sensitivity to electrical hazards (e.g. cardiac failure) to work with the machine.
- ▶ Wear dry safety shoes, dry metal-free (grommet-free) leather gloves and dry safety suits to minimize the electrical hazard.
- ▶ Work on a dry surface.

### DANGER



**The rotation movement of the rotor can cause hair, jewelry or clothes to be caught and pulled into the enclosure.**

- ▶ Wear tight-fitting clothes.
- ▶ Do **not** wear open hair, jewelry or other accessories that can be easily drawn in.

### CAUTION



**The rotor can start up unexpectedly during the setup of the electrode.**

Risk of crushing of hands and fingers!

- ▶ Before mounting the electrodes: Switch off the power supply.
- ▶ To move the rotor to home position: Close the clamping cassette or the clamping unit and flip cover.

### CAUTION



**Danger of being pricked by the electrode for the operator as well as for third parties while taking hold of the orbital weld head.**

- ▶ Do **not** grasp the orbital weld head at the position of the electrode.
- ▶ Wear safety gloves DIN 12477, Type A for welding operation and DIN 388, Class 4 for mounting the electrode.

### CAUTION



**Unintentional starting up of the weld head!**

Crushing at hands and fingers.

- ▶ Switch off the welding power source before the weld head is connected.

To reach the optimum welding quality a current adjusted to the electrode geometry is necessary. This is defined by the electrode diameter, the tip diameter and the cutting angle.

- ▶ The electrode must be replaced every time its geometry clearly deviates from the original.

To be able to reproduce welding the electrode gap to the workpiece must remain unchanged. In order to ensure this, after the gap of the electrode to the workpiece is adjusted, the electrode projection from the gas nozzle must be measured.

- Check determined electrode projection before each new welding and, if necessary, adjust it.

**INFO**

Electrode holders for electrodes are available with a diameter of 1; 1,6; 2; 2,4 mm

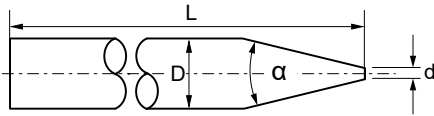

Illustration: Electrode geometry parameters

The following table shows the parameters to be maintained: electrode diameter  $D$ , electrode tip diameter  $d$  and cutting angle  $\alpha$  depending on the current. The length  $L$  of the electrode is variable.

ELECTRODE DIAMETER $D$		TIP DIAMETER $D$		ANGLE $A$	DIRECT CURRENT MAX.	PULSE CURRENT STABILITY FIELD
[mm]	[in]	[mm]	[in]	[°]	[A]	[A]
1.0	0,039	0.12	0,005	12	15	2 - 25
1.0	0,039	0.25	0,010	20	30	5 - 60
1.6	0,063	0.50	0,020	25	50	8 - 100
1.6	0,063	0.75	0,030	30	70	10 - 140
2.05	0,081	0.75	0,030	35	80	10 - 160
2.4	0,094	0.75	0,030	35	90	12 - 180
2.4	0,094	1.1	0,043	45	150	15 - 250
3.2	0,126	1.1	0,043	60	200	20 - 300
3.2	0,126	1.5	0,059	90	250	25 - 350

## 8.6 Fit centering unit

- ✓ Optional cold wire conveyor unit is fitted.
- ✓ Weld head is hung on the spring balancer.

The centering unit guarantees that the arc is turned around the pipe axis precisely in the gap of the half pipe diameter during welding.

A spindle is screwed to the cover before the torch, onto which a centering cartridge can then be pushed and engaged.

### NOTICE!



### Damage to the centering unit

- ▶ Spindles and centering cartridges must be selected according to inner diameter of the pipe. *See the chapter* Application area [▶ 25]

- ▶ Release the 5 pre-fitted fastening screws (2) from the cover (1) with a hexagon screwdriver and bolt the spindle (3) to the cover.

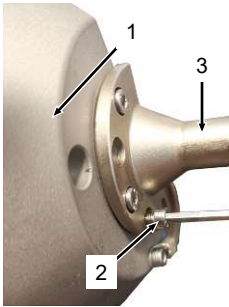

- ▶ Push centering cartridge (6) over the ball spring (4) onto the spindle (3). The resistance must be great enough that the centering cartridge can still be pushed over and pulled off the ball spring by hand, but is securely held in place.
  - ⇒ If the resistance is too low, turn grub screw (5) clockwise in the tip of the spindle with a hexagon screwdriver in order to increase the resistance.
  - ⇒ If the resistance is too high, turn grub screw (5) counterclockwise in the tip of the spindle with a hexagon screwdriver in order to decrease the resistance.

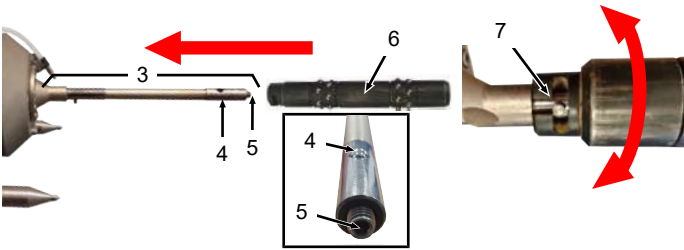

- ▶ Completely push centering cartridge onto the spindle and engage in the bayonet lock (7).

## 8.7 Clamp the weld head in the workpiece

- ✓ Optional cold wire conveyor unit is fitted. *See the chapter* Fit cold wire conveyor unit (optional) [▶ 39]
- ✓ Weld head is positioned balanced. *See the chapter* Hang the weld head on the spring balancer [▶ 44]
- ✓ Centering unit is fitted to the weld head. *See the chapter* Fit centering unit [▶ 53]
- ▶ Position centering cartridge (1) in the center before the pipe opening and push into the pipe until touching the three support feet (2) on the pipe sheet (3).

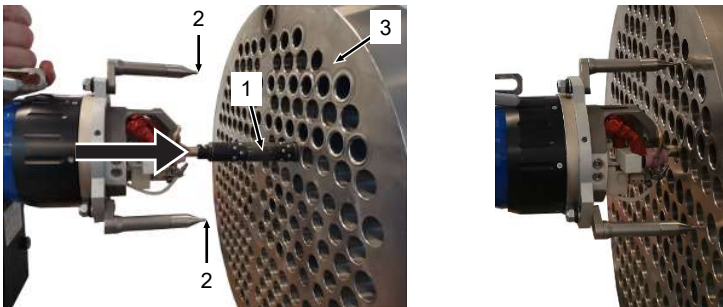

## 8.8 Adjust welding diameter

The torch has one mounting position for welding pipes with a smaller diameter and another for welding pipes with a larger diameter.

See *the chapter* Change mounting position of gas lens/nozzle on torch body [► 55]

**NOTICE!** After each change of torch position screw closed the mounting opening with the Teflon insulating plug.

The precise welding diameter is then finely adjusted with the adjusting screw.

See *chap.* Finely adjust welding diameter [► 56]

### 8.8.1 Change mounting position of gas lens/nozzle on torch body

The torch body has two mounting openings for the gas lens: An outer one for larger welding diameters and an inner one for smaller welding diameters.

Depending on application, the mounting position of the gas nozzle/lens can be changed on the torch body.

- Raise bracket (2) of HF spiral (1) and pull from the gas nozzle (3).

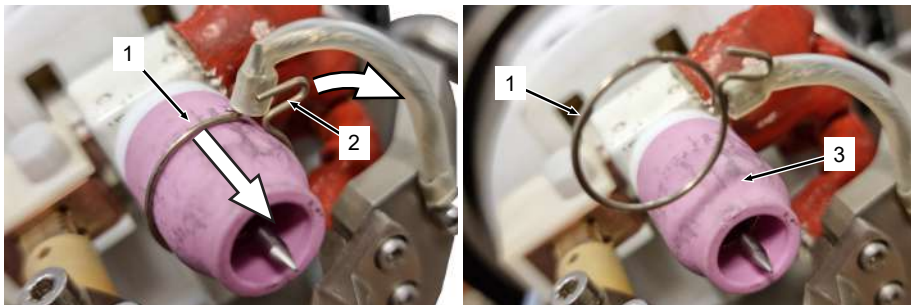

- ▶ Screw gas nozzle (3) counterclockwise from the gas lens (4).
- ▶ Turn gas lens (4) counterclockwise from its thread and remove with the torch insulator (5).

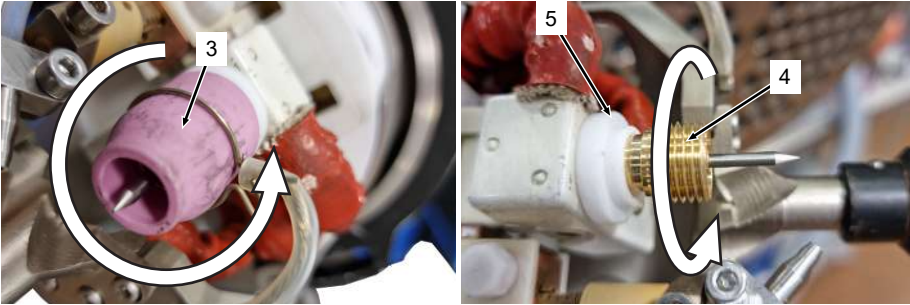

- ▶ Unscrew Teflon insulating plug (6) with a slot screwdriver from the desired mounting opening and screw into the unused one.

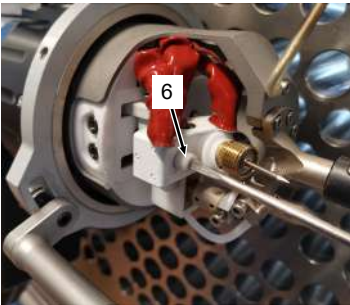

- ▶ Turn gas lens with torch insulator clockwise into the desired mounting opening.
- ▶ Turn gas nozzle clockwise on the gas lens.

## 8.8.2 Finely adjust welding diameter

- ✓ Optional cold wire conveyor unit is fitted. *See the chapter* Fit cold wire conveyor unit (optional) [▶ 39]
- ✓ Weld head is positioned balanced. *See the chapter* Hang the weld head on the spring balancer [▶ 44]
- ✓ Centering unit is fitted to the weld head. *See the chapter* Fit centering unit [▶ 53]
- ✓ Weld head is taut in workpiece. *See the chapter* Clamp the weld head in the workpiece [▶ 54]



- ▶ Adjust desired radius of the torch to the pipe center with a hexagon screwdriver at the adjusting screw (4).

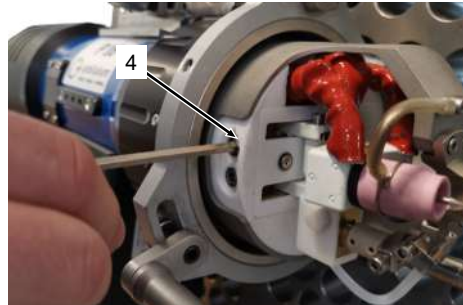

### 8.8.3 Adjust torch angle

- ✓ Optional cold wire conveyor unit is fitted. *See the chapter* Fit cold wire conveyor unit (optional) [▶ 39]
- ✓ Weld head is positioned balanced. *See the chapter* Hang the weld head on the spring balancer [▶ 44]
- ✓ Centering unit is fitted to the weld head. *See the chapter* Fit centering unit [▶ 53]
- ✓ Weld head is taut in workpiece. *See the chapter* Clamp the weld head in the workpiece [▶ 54]
- ✓ Welding diameter is finely adjusted. *See the chapter* Finely adjust welding diameter [▶ 56]

Release hexagon socket head screw (2) in torch body (1) with a hexagon screwdriver.

Incline torch to the pipe axis by maximum 30° by hand and retighten hexagon socket head screw (2).

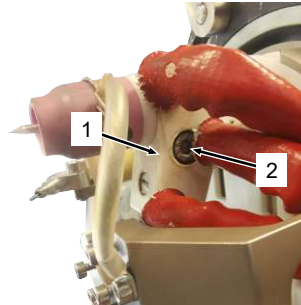

## 8.9 Adjust welding gap

With the fine adjustment ring the gap of the electrode to the workpiece can be adjusted by +/- 5 mm.

- ✓ Optional cold wire conveyor unit is fitted. *See the chapter* Fit cold wire conveyor unit (optional) [▶ 39]
- ✓ Weld head is positioned balanced. *See the chapter* Hang the weld head on the spring balancer [▶ 44]
- ✓ Centering unit is fitted to the weld head. *See the chapter* Fit centering unit [▶ 53]
- ✓ Weld head is taut in workpiece. *See the chapter* Clamp the weld head in the workpiece [▶ 54]
- ✓ Welding diameter is adjusted. *See the chapter* Adjust welding diameter [▶ 55]
- ✓ Welding diameter is finely adjusted. *See the chapter* Finely adjust welding diameter [▶ 56]

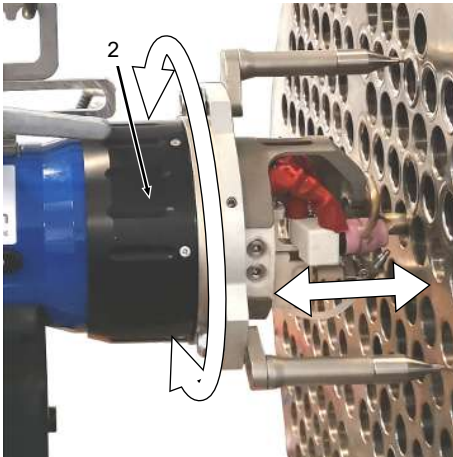

- ▶ Turn fine adjustment ring (2) clockwise/counterclockwise until the electrode tip has the desired gap to the workpiece.

## 8.10 Position wire nozzle

**NOTICE!** Applies to weld heads with cold wire conveyor unit only.

- ✓ Optional cold wire conveyor unit is fitted. *See the chapter* Fit cold wire conveyor unit (optional) [▶ 39]
- ✓ Weld head is positioned balanced. *See the chapter* Hang the weld head on the spring balancer [▶ 44]
- ✓ Centering unit is fitted to the weld head. *See the chapter* Fit centering unit [▶ 53]
- ✓ Weld head is taut in workpiece. *See the chapter* Clamp the weld head in the workpiece [▶ 54]
- ✓ Welding diameter is adjusted. *See the chapter* Adjust welding diameter [▶ 55]
- ✓ Welding diameter is finely adjusted. *See the chapter* Finely adjust welding diameter [▶ 56]
- ✓ Welding gap is adjusted. *See the chapter* Adjust welding gap [▶ 58]

The position of the **complete wire unit** can be axially adjusted via the adjusting screw (6).

Furthermore, the **position of the wire nozzle** (4) can be adjusted axially via the adjusting screw (1), horizontally via the hexagon socket head screw (2) and vertically via the hexagon socket head screw (3).

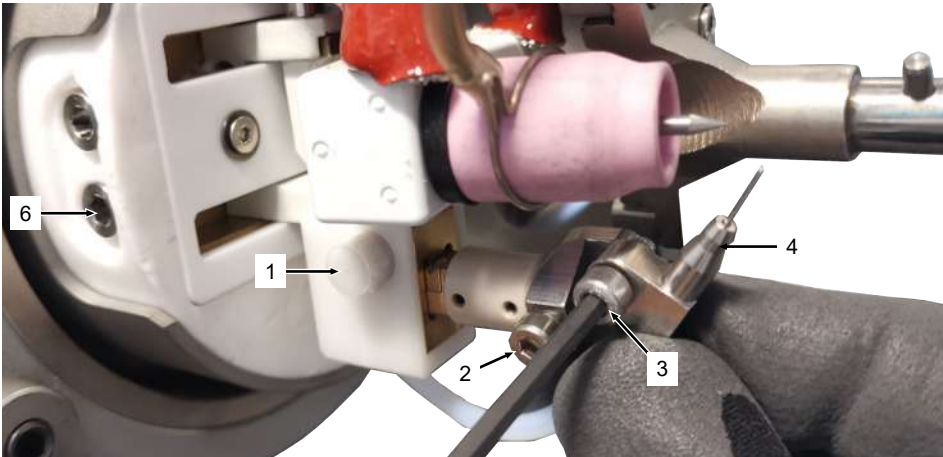

#### Adjust axially:

1. Release locking screw (5) with an Allen key.

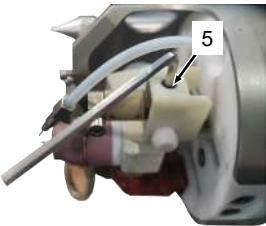

*Illustration: Wire nozzle axial displacement locking screw*

2. Turn adjusting screw (1) clockwise with an Allen key: Wire nozzle (4) is moved to the workpiece.
3. Turn adjusting screw (1) counterclockwise with an Allen key: Wire nozzle is moved to the torch.

#### Adjust horizontally:

- ▶ Release hexagon socket head screw (2) with a hexagon screwdriver, position wire nozzle (4) by hand and retighten hexagon socket head screw.

#### Adjust vertically:

- ▶ Release hexagon socket head screw (3), position wire nozzle (4) by hand and retighten.

## 8.11 Carry out the gas and cooling-liquid function test

At the initial operation or if the weld head is not filled, wait a minute until the weld head is filled with cooling liquid.

► *See operating instructions of the welding power source*

## 8.12 Calibrating the motor

If several weld heads of the same type are in use, it is recommended that the motors be calibrated before use. This allows identical welding results to be realized with the saved programs and all weld heads.

► *See operating instructions of the welding power source*

## 9 Operation

Operation of the weld head takes place via the keypad on the handle and/or via the welding power supply (see *operating instructions of the welding power supply*).

### 9.1 Weld mode

#### WARNING



#### Risk of injury due to radiation or heat!

Contact with hot workpieces and sparks leads to burns.

- ▶ Use welding shield or welding helmet with sufficient protective level (depending on use).
- ▶ Wear dry protective clothing (e.g. welding shield, gloves, etc.) according to the applicable regulations of the respective country.
- ▶ Protect uninvolved persons with protective curtains or walls against radiation and glare.

#### DANGER



#### Electromagnetic fields arise during the welding process.

- ▶ The plant operator must realize the workplaces in accordance with the EMF Directive 2013/35/EU in such a manner that no danger whatsoever exists for the operator or persons in the vicinity of the welding system.

#### DANGER



#### If the argon share in the air rises above 50%, lasting damage or risk of death can arise through suffocation.

- ▶ Ensure sufficient ventilation in rooms.
- ▶ If necessary, monitor the oxygen level in the air.

#### WARNING



#### Thermal problems can arise in the case of incorrect positioning of the forming system or the use of impermissible materials in the welding area.

In the worst case a fire will be started.

- ▶ Observe the local general fire protection measures.

#### NOTICE!



#### Various risks

- ▶ Permanently observe welding process!

- ✓ Welding power supply, ground cable and weld head are connected, aligned and ready for operation.
- ▶ Press the **“START/STOP”** (1) key to start the welding process.

OR via welding power supply:

- ▶ See *operating instructions of the welding power source*.
- ⇒ The welding process ends automatically after the gas post purge time has expired.

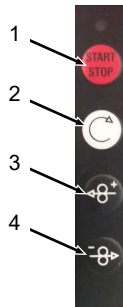

## 9.2 Aborting welding

- ▶ Press **“START/STOP”** key (1) on the control panel of the weld head. The current process is stopped. Only the programmed gas post purge time continues to run.
- By pressing the **“START/STOP”** key again during the gas post purge time this is also stopped.

OR via welding power supply:

- ▶ See *operating instructions of the power source*

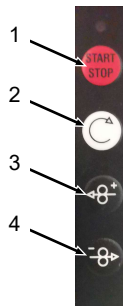

## 9.3 Returning the weld head to home position

- ✓ The gas post purge time has ended.
- ▶ Press and hold **“ROTATION CLOCKWISE”** button (2).
- ⇒ Weld head moves to home position.

OR via welding power supply:

- ▶ See *operating instructions of the welding power source*.

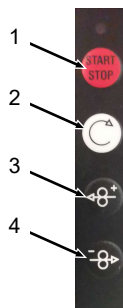

## 9.4 Removing the weld head from the workpiece

- ✓ The rotor is in home position.  
See the chapter Returning the weld head to home position [▶ 63]
- ▶ Hold weld head on handle/motor and pull centering unit from the workpiece.

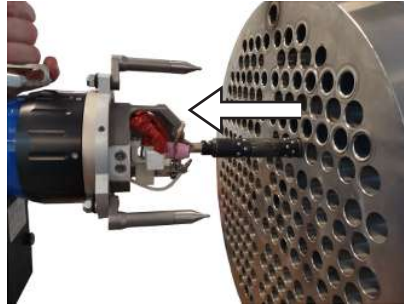

## 9.5 Manual wire feed and retraction

### Manual wire feed:

- ▶ Press and hold "WIRE FEED" button (4).  
⇒ The wire is moved in the direction of the torch.

### Manual wire retraction:

- ▶ Press and hold "WIRE RETRACTION" button (3).  
⇒ The wire is pulled onto the coil.

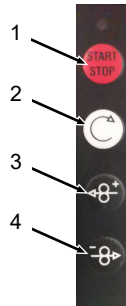

### OR via welding power supply:

- ▶ See operating instructions of the welding power source.



## 9.6 Preparing storage

Carry out the following steps before storage:

1. Switch off the welding power supply.
2. Disconnect the weld head from the welding power supply, see chap. Connecting the weld head to the power source.
3. Remove electrode, see chap. Set up the electrode.
4. Store weld head. Ensure that the power/gas hose is not twisted or squeezed.

Carry out the following steps additionally before longer storage periods:

1. Clean the surfaces.
2. Store dry and dust-free.

The following storage conditions must be observed:

- Storage only in enclosed spaces
- Do not store near materials that may cause corrosion.
- Temperature range -20 to +55 °C
- Relative humidity up to 90 % at 40 °C

*Further care and maintenance advice, see chap. Maintenance and troubleshooting.*

# 10 Maintenance and troubleshooting

## 10.1 Instructions for care

- ▶ Ensure that **no** dirt particles or small parts enter the transmission (inside weld head).
- ▶ If the surfaces are soiled, use only residue-free cleaning agents for cleaning.

## 10.2 Maintenance and care

The following instructions for care depend, if not stated otherwise, strongly on the usage of the weld head.

Shorter cleaning intervals influence the equipment service life positively.

INTERVAL	ACTIVITY
Before every use	<ul style="list-style-type: none"> <li>▶ Check the hose package and weld head for damage.</li> <li>▶ Check the electrode.</li> </ul>
Regularly (depending on usage)	▶ Regularly remove visible dirt.
After about every 20th welding seam	▶ Replace or regrind the electrode.
At least every 250 welding processes	<ul style="list-style-type: none"> <li>▶ Carry out the standard cleaning process of the weld head (see <i>chap.</i> Standard cleaning process [▶ 67]).</li> <li>▶ A shorter cleaning interval can influence the service life of the weld head positively.</li> </ul>

## 10.2.1 Standard cleaning process

### NOTICE!



Cleaning work on the welding tongs may only be carried after it has cooled down completely!

### NOTICE!



Cleaning of the welding tongs should be carried out at least every 500 welding processes. Shorter cleaning intervals influence the equipment service life positively.

### CAUTION



**The use of lubricants can severely influence the function and cause damage.**

- ▶ Never spray lubricant **into** the welding tongs!

### CAUTION



**Unintentional starting up of the weld head!**

Crushing of hands and fingers.

- ▶ Switch off the Orbital welding power source.

#### Required cleaning materials:

- Lint-free cotton cloth
- Fine sandpaper
- Hexagon screwdriver
- Spanner

#### Clean external surfaces:

- ▶ Clean surfaces with lint-free cotton cloth.
- ▶ Remove foreign matter from the gas nozzle and gas lens. In the case of stubborn soiling, a Scotch-Brite cleaning sponge or a comparable product can be used.

#### Clean contact surfaces:

- ▶ Unscrew bolt (2) with Allen key.

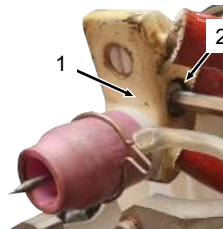

- ▶ Take torch body (1) from the holder.



- ▶ Remove sooting on the contact surfaces of the torch body (1) and torch holder (3) with fine sandpaper.

- ▶ Unscrew bolt (4) with Allen key.

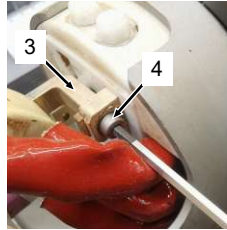

- ▶ Take torch holder (3) from the carriage (5).

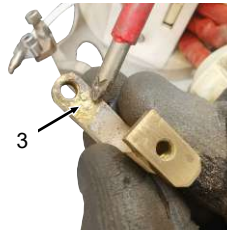

- ▶ Clean carriage (5) of the radial torch adjustment with a lint-free cotton cloth.

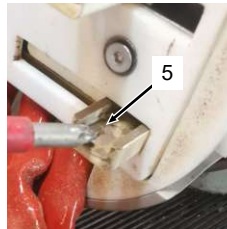

- ▶ To mount carry out work steps in reverse order.

Clean coupling of wire coil:

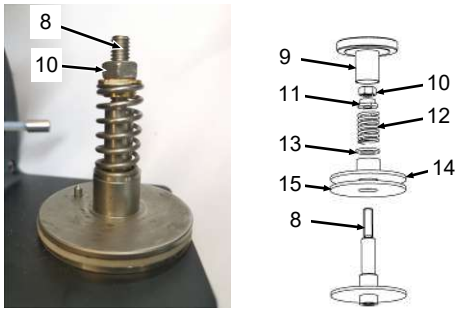

1. Bolt knurled nut (9) from the arbor shaft (8).
2. Screw nut (10) from the arbor shaft (8) with a spanner.
3. Take parts (10) to (15) from the arbor shaft.
4. Clean friction surfaces of the arbor shaft (8), the coupling (15) and the clutch disc (14) with a lint-free cotton cloth.

► To mount carry out work steps 1–3 in reverse order.

## 10.3 Troubleshooting

PROBLEM	POSSIBLE CAUSE	REMEDY
Welding process does not start.	No gas supply.	<ul style="list-style-type: none"> <li>▶ Check the connections at the welding power supply.</li> <li>▶ Check the hoses, gas bottle and pressure reducer.</li> </ul>
Weld head does not clamp correctly on the workpiece.	Hose diameter does not fit the clamping jaw/clamp arm.	▶ Use clamping jaws that fit or remove the clamping jaws.
Continuously large and constantly different speed deviations.	Defect at the welding power supply or weld head.	▶ Contact Service.
Arc does not ignite.	Weld head and ground cable incorrectly connected.	1. Clean the workpiece and contact clamp.
	Contact fault between workpiece and contact clamp.	2. Remove isolating intermediate layers.
	Workpieces soiled.	▶ Clean the workpiece.
	Welding gas concentration too low.	▶ Check welding gas supply and quantity.
	Electrode distance too large.	▶ Set the electrode distance. Adjust welding gap [▶ 58]
	Electrode tip worn.	▶ Regrind the electrode. <i>See chap. Grinding electrode [▶ 51]</i>
	Cable break.	▶ Replace power/gas cable.
Arc tends to one side.	Electrode worn.	▶ Regrind the electrode. <i>See chap. Grinding electrode [▶ 51]</i>
	Electrode ground incorrectly.	▶ Regrind the electrode. <i>See chap. Grinding electrode [▶ 51]</i>
	Poor electrode quality.	▶ Use Orbitalum electrodes. <i>See the chapter</i>
	Incorrect workpiece material	▶ Change workpiece material.
	Bad workpiece quality	▶ Use different material batch.

PROBLEM	POSSIBLE CAUSE	REMEDY
Rotation movement does not start.	Foreign matter in the transmission.	► If possible, remove the foreign matter by means of a vacuum unit. Otherwise send the weld head to the Service. Under no circumstances let the rotor rotate.
	Connection faulty.	► Check the plug and welding power supply.

## 10.4 Replace wire guide nozzle

Replacement is necessary if the hole of the wire guide nozzle no longer guarantees a precise routing of the wire due to wear and also if it is desired to use a wire with a different diameter.

**Nozzles for the following wire diameter are available:**

**[mm]**

0.6

0.8

1.0

1.2

1. Release hexagon socket head screw (3) with hexagon screwdriver.
2. Take nozzle (2) from the support (1) and hold in such a way that the wire guide hose (4) has no kinks.
3. Unscrew nozzle (2) from the wire guide hose (4).
4. Unscrew new nozzle.
5. Place nozzle (2) in the support (1) and tighten hexagon socket head screw (3) with hexagon screwdriver.

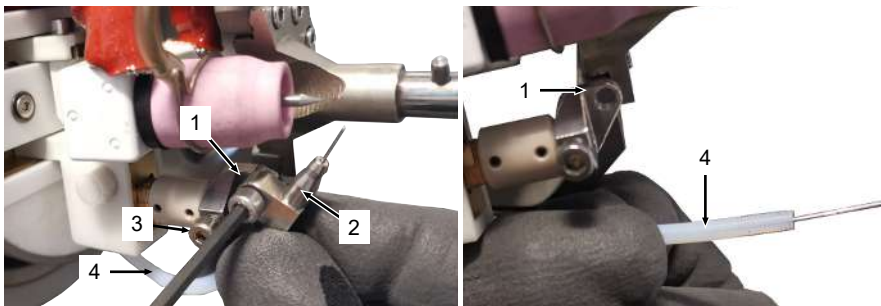

## 10.5 Replace wire guide hoses

The wire guide hoses are subject to wear and should be replaced after use of approx. 10-15 wire coils in order to ensure resistance-free gliding of the wire.

### Replace front wire guide hose:

- ✓ Protective cover, wire guide nozzle and wire coil are removed, the wire remaining in the weld head is removed (see *chapter* Remove wire coil [▶ 40]).
1. Unscrew and remove cold wire supply unit (1). The front hose (2) is pulled out of the weld head.

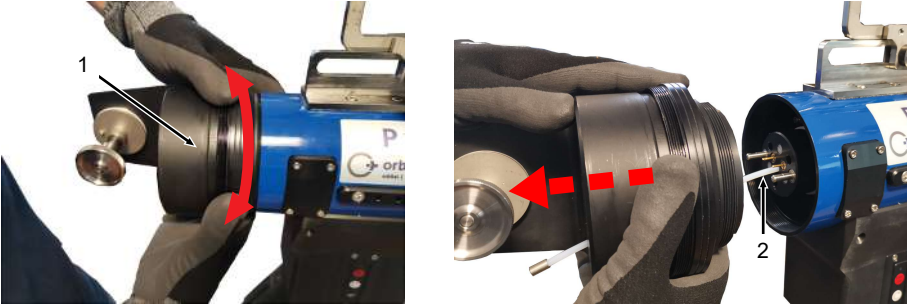

2. Turn and pull out the other end of the hose from the guide nozzle of the cold wire supply unit.
3. Sharpen end of the new hose (e.g. with a pencil sharpener).
4. Cut off approx. 2 mm (0.1 in) of the hose ends with a sharp knife (e.g. with a carpet knife) in order to remove any burrs created.
5. Turn hose through the guide channel (3) of the cold wire supply unit into the guide nozzle (hose is self-cutting).





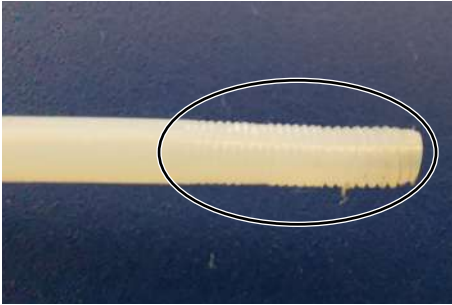

Illustration: Thread in wire guide hose

6. Push front hose end in a turning movement through the guide channel in the weld head until it comes out of the front channel opening.
7. Turn wire guide nozzle onto the hose (hose is self-cutting).
8. Mount wire guide hose in its holder (see *chap.* Replace wire guide nozzle [▶ 71])

### Replace rear wire guide hose

- ✓ Protective cover, wire guide nozzle and wire coil are removed, the wire remaining in the weld head is removed (see *chapter* Remove wire coil [▶ 40]).

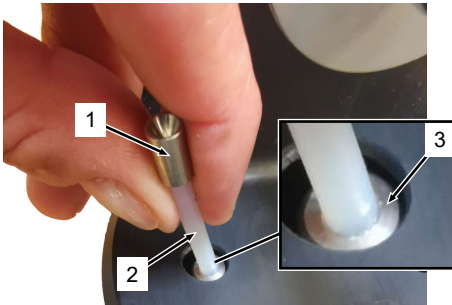

Illustration: Turn rear wire guide hose in/out

1. Turn wire guide nozzle (1) of old hose and keep safe.
2. Turn old hose from the wire guide nozzle (3) and remove.
3. Sharpen end of the new hose (e.g. with a pencil sharpener).
4. For deburring, cut off approx. 2 mm (0.1 in) of the hose ends with a sharp knife (e.g. with a carpet knife) in order to remove any burrs created.
5. Screw a hose end into the wire guide nozzle (3) of the cold wire supply unit (the hose is self-cutting).

6. Turn wire guide nozzle (1) from the old hose to the other end of the new one (the hose is self-cutting).

## 10.6 Service and customer support

### 10.6.1 Customer support

Our products are extremely robust and reliable. To ensure the performance in the long run, the recommended service and maintenance intervals should be performed regularly.

We offer competent service via branches as well as our worldwide network of authorized partners. These are carefully selected and are regularly trained by our experts to always be up-to-date with regard to products and technologies.

All service and maintenance work is performed with great care by qualified and motivated employees. They analyze your situation to find the best long-term solution.

Service contact at Orbitalum GmbH Singen:

E-mail: [customerservice@orbitalum.com](mailto:customerservice@orbitalum.com)

Phone: +49 (0) 77 31 792-786

If you require service, please download our "Service Form" from the Orbitalum home page at Service & Repairs and enclose the completed form with the shipment of the affected goods.

### 10.6.2 Technical support & application engineering

Do you have questions about the operation of your Orbitalum system or do you have a technical problem?

Our experienced and qualified product and application specialists will support you in the correct selection and application of products.

In order to process your request as efficiently as possible, please provide us with the serial number of the equipment concerned when contacting us. This way we will have an initial overview.

- Handling of technical inquiries and problems
- Systematic fault diagnosis and correction
- Support in the selection of the right spare parts
- Support during operation, commissioning and test runs
- Support by telephone, by e-mail and on request also at your facility

E-mail: [tech.support@orbitalum.com](mailto:tech.support@orbitalum.com)

Phone: +49 (0) 77 31 792-764

### 10.6.3 Operator and service training

Our specialist knowledge is imparted by our own experts in small groups in our modern training rooms in Singen. This makes it possible to respond to each individual participant and address specific questions. We will gladly conduct training at your facility upon request.

At the end of each training you will receive a certificate of attendance and a certificate confirming that you have acquired the required knowledge.

Operators from the plant, container and pipeline construction industries are particularly suitable as target groups for the various training courses.

E-mail: [training@orbitalum.com](mailto:training@orbitalum.com)

Phone: +49 (0) 77 31 792-741

# 11 ERSATZTEILLISTE / SPARE PARTS LIST



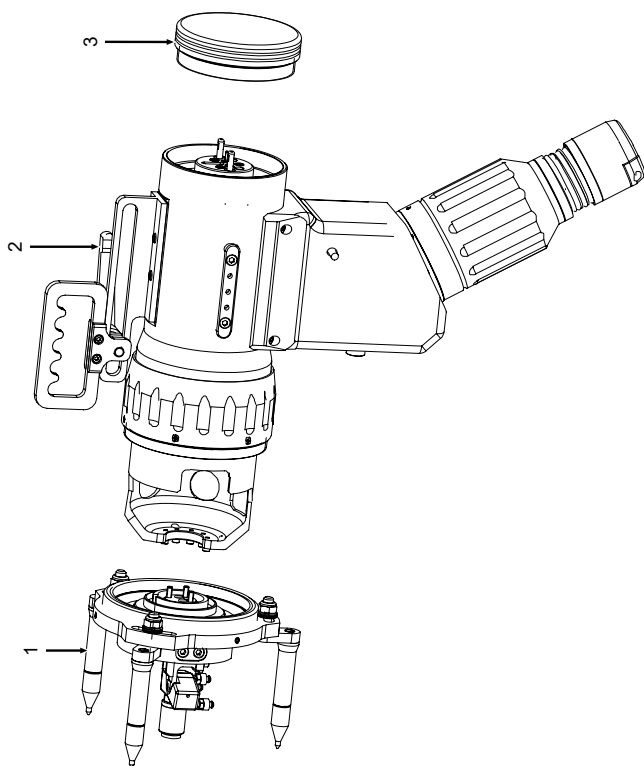

## 11.1 P16 EVO | P16 EVO

POS. NO.	CODE PART NO.	STK. QTY.	BEZEICHNUNG DESCRIPTION
1	833 050 050	1	Brenner P16 EVO, kpl. Torch group P16 EVO
2	833 050 030	1	Grundkörper P16 EVO, kpl. Base body P16 EVO
3	831 001 170	1	Abschlusskappe Cap

## 11.2 P16 EVO mit KD | P16 EVO with KD

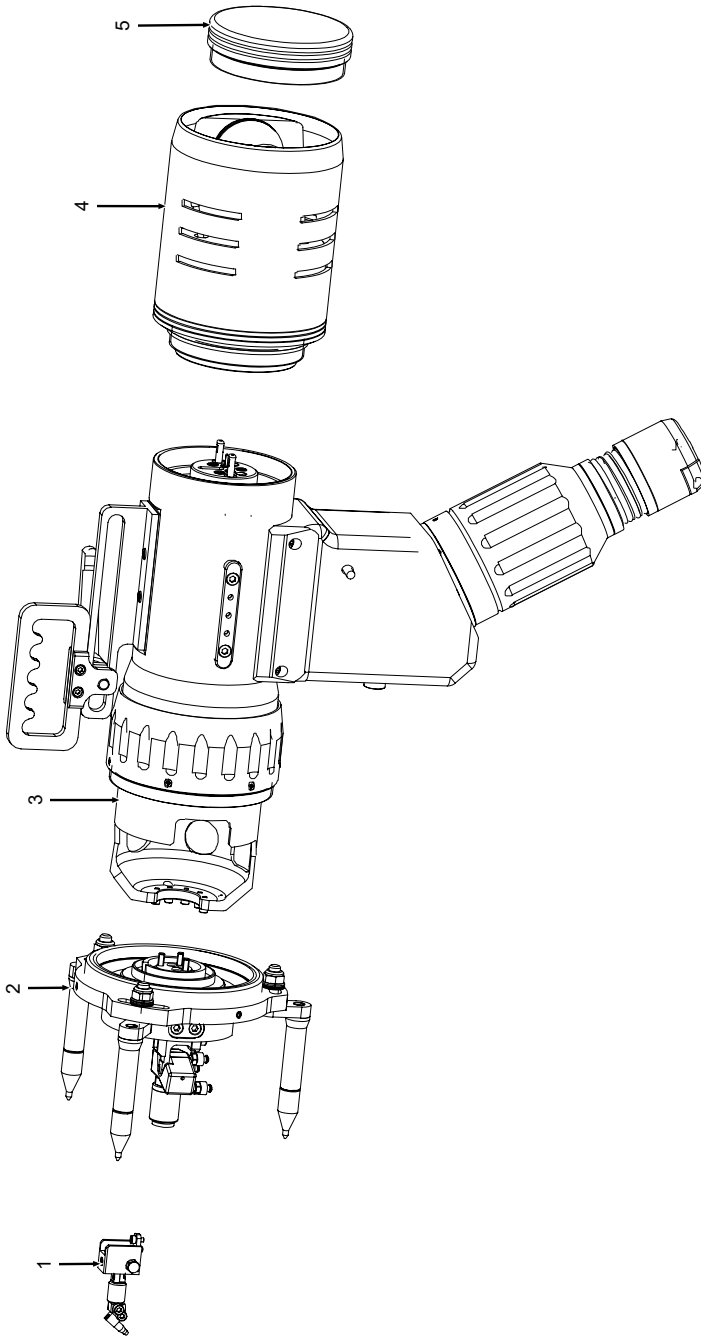

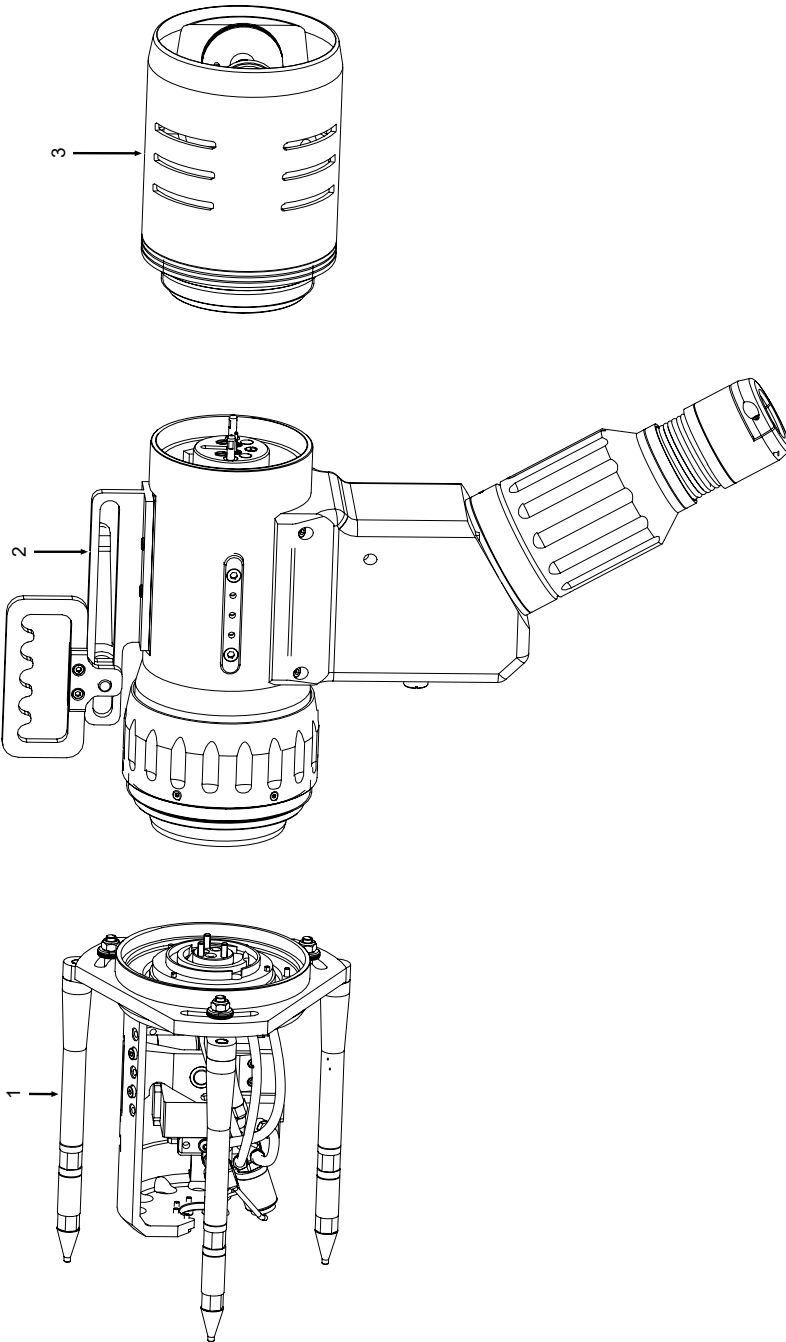

POS. NO.	CODE PART NO.	STK. QTY.	BEZEICHNUNG DESCRIPTION
1	831 001 030	1	Drahtverstellungsgruppe P16 EVO, kpl. Wire adjustment group P16, complete
2	833 050 050	1	Brenner P16 EVO, kpl. Torch group P16 EVO
3	833 050 030	1	Zentralkörper P16 EVO, kpl. Base body P16 EVO
4	833 001 116		Kaltdrahtzuführung P16/P16AVC EVO Cold wire unit P16/P16AVC EVO
5	831 001 170	1	Abschlusskappe Cap

**11.3 P16 EVO AVC | P16 EVO AVC**

POS. NO.	CODE PART NO.	STK. QTY.	BEZEICHNUNG DESCRIPTION
1	833 050 090	1	Brenner P16 AVC EVO, kpl. Torch group P16 AVC EVO
2	833 050 080	1	Zentralkörper P16 AVC EVO, kpl. Base body P16 AVC EVO
3	833 001 116	1	Kaltdrahtzuführung P16/P16AVC EVO Cold wire unit P16/P16AVC EVO

# 11.4 Grundkörper Übersicht P16 EVO m/o KD | Base body overview P16 EVO w/o Cold wire unit

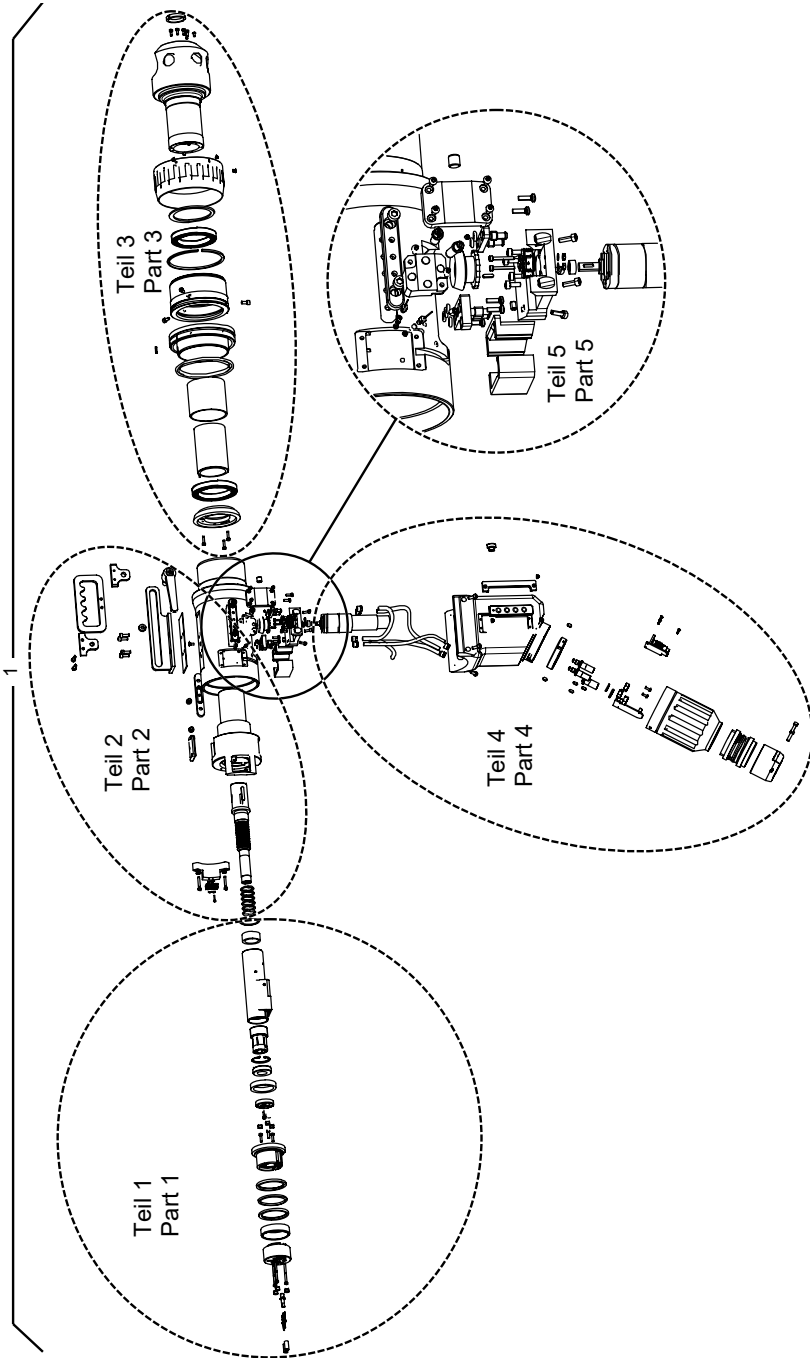

TEIL PART	BEZEICHNUNG DESCRIPTION
1	<p>Grundkörper Teil 1, P16 EVO ohne Kaltdraht</p> <p>Base body Part 1, P16 EVO without cold wire unit</p> <p>Grundkörper Teil 1, P16 EVO mit Kaltdraht</p> <p>Base body Part 1, P16 EVO with cold wire unit</p>
2	<p>Grundkörper Teil 2, P16 EVO ohne Kaltdraht</p> <p>Base body Part 2, P16 EVO without cold wire unit</p> <p>Grundkörper Teil 2, P16 EVO mit Kaltdraht</p> <p>Base body Part 2, P16 EVO with cold wire unit</p>
3	<p>Grundkörper Teil 3, P16 EVO ohne Kaltdraht</p> <p>Base body Part 3, P16 EVO without cold wire unit</p> <p>Grundkörper Teil 3, P16 EVO mit Kaltdraht</p> <p>Base body Part 3, P16 EVO with cold wire unit</p>
4	<p>Grundkörper Teil 4, P16 EVO ohne Kaltdraht</p> <p>Base body Part 4, P16 EVO without cold wire unit</p> <p>Grundkörper Teil 4, P16 EVO mit Kaltdraht</p> <p>Base body Part 4, P16 EVO with cold wire unit</p>
5	<p>Grundkörper Teil 5, P16 EVO ohne Kaltdraht</p> <p>Base body Part 5, P16 EVO without cold wire unit</p> <p>Grundkörper Teil 5, P16 EVO mit Kaltdraht</p> <p>Base body Part 5, P16 EVO with cold wire unit</p>

### 11.4.1 Grundkörper m/o KD | Base body w/o KD

## Teil 1 Part 1

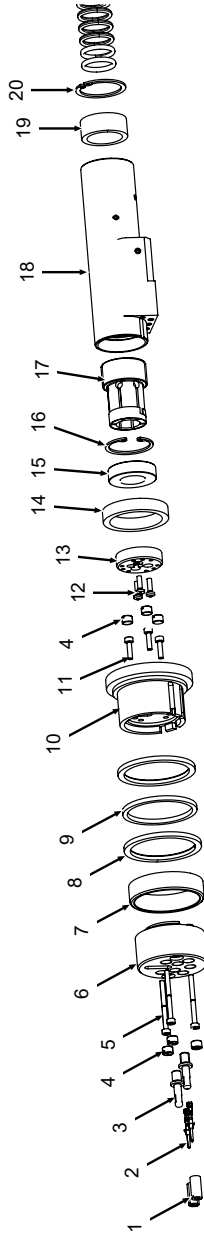

POS. NO.	CODE	STK. QTY.	BEZEICHNUNG DESCRIPTION	POS. NO.	CODE	STK. QTY.	BEZEICHNUNG DESCRIPTION
1	831 007 108	2	Messingbuchse Brass bush	11	305 501 055	3	Zylinderschraube ISO4762-M3x12-A2 Cylinder screw ISO4762-M3x12-A2
2	831 007 070	2	Steckkontakt, vergoldet Plated pin, gilt	12	305 501 080	3	Zylinderschraube ISO4762-M3x8-A2-VA Cylinder screw ISO4762-M3x8-A2-VA
3	831 007 010	2	Bolzen Bolt	13	831 007 009	1	Anschlagscheibe Stop washer
4	848 007 033	6	Gewindestopfen Screw plug	14	831 007 073	1	Zentriering Centerring
5	305 501 091	3	Zylinderschraube ISO4762-M3x35-A2 Cylinder screw ISO4762-M3x35-A2	15	831 007 053	1	Gleitlager Slide bearing
6	831 007 026	1	Isolierflansch Insulating flange	16	554 058 330	1	Sicherungsring DIN472-30x1.2 Circlip DIN472-30x1.2
7	831 007 008	1	Isolierkollektoring Insulating collector ring	17	831 001 235	1	Graphitkupplung P16/P20 Graphite clutch P16/P20
8	831 007 006	2	Kollektoring collector ring	18	831 007 110	1	Messingkörper, Rotationskupplung Brass body, redation coupling
9	831 007 007	1	Isolierkollektoring Insulating collector ring	19	831 007 058	1	Gleitlager Slide bearing
10	831 007 005	1	Kollektorflansch Collector flange	20	554 058 332	1	Sicherungsring D32x1.2 Retaining ring D32x1.2

# Teil 2 Part 2

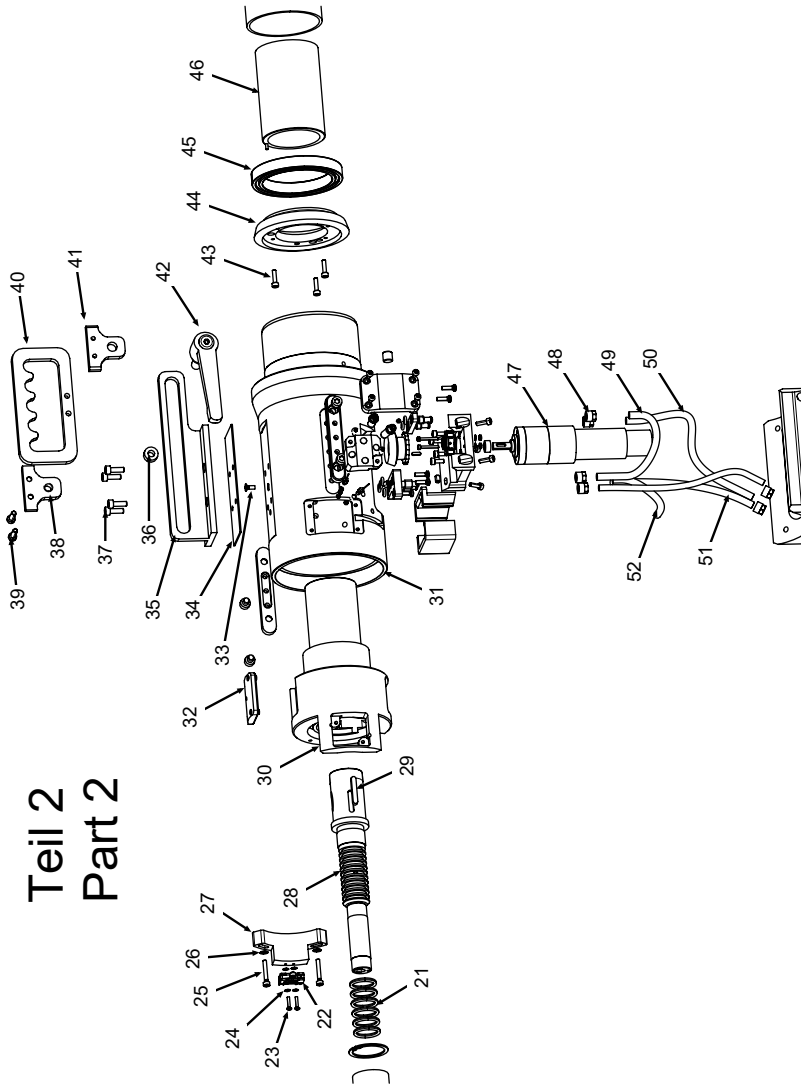



POS. NO.	CODE	STK. QTY.	BEZEICHNUNG DESCRIPTION	POS. NO.	CODE	STK. QTY.	BEZEICHNUNG DESCRIPTION
21	831 001 052	6	O-Ring PRP 116 O-ring PRP 116	31	831 007 002	1	Maschinenkörper P16 Machine body P16
22	831 050 100	2	Mikroschalter, kpl. Microswitch, cpl.	32	831 007 003	1	Platte, klein Plate, small
23	305 501 048	2	Zylinderschraube ISO4762-M2x16-A2 Cylinder screw ISO4762-M2x16-A2	33	302 301 051	1	Senkschraube ISO10642-M3x8-A2 Countersunk screw ISO10642-M3x8-A2
24	542 500 326	10	Scheibe DIN125-ISO7089-Ø2.2-A2 Washer DIN125-ISO7089-Ø2.2-A2	34	831 007 050	1	Filzunterlage Felt pad
25	305 501 058	2	Zylinderschraube ISO4762-M3x20-A2 Cylinder screw ISO4762-M3x20-A2	35	833 007 003	1	Bügel Clamp
26	542 500 325	2	Scheibe D3.2 Washer D3.2	36	828 008 015	1	Buchse Bushing
27	831 007 076	1	Halterung Mikroschalter Holder microswitch	37	305 501 070	4	Zylinderschraube ISO4762-M4x12-A2 Cylinder screw ISO4762-M4x12-A2
28	831 007 121	1	Achse Rotationskupplung V2 Axis rotary clutch V2	38	833 007 001	1	Blech rechts Sheet right
29	565 000 120	1	Passfeder 4x4x25 A Feather key 4x4x25 A	39	305 501 074	2	Zylinderschraube ISO4762-M4x14-A2 Cylinder screw ISO4762-M4x14-A2
30	831 007 004	1	Isolierkörper Insulating body	40	833 007 049	1	Aufhängung Suspension

# Teil 2 Part 2

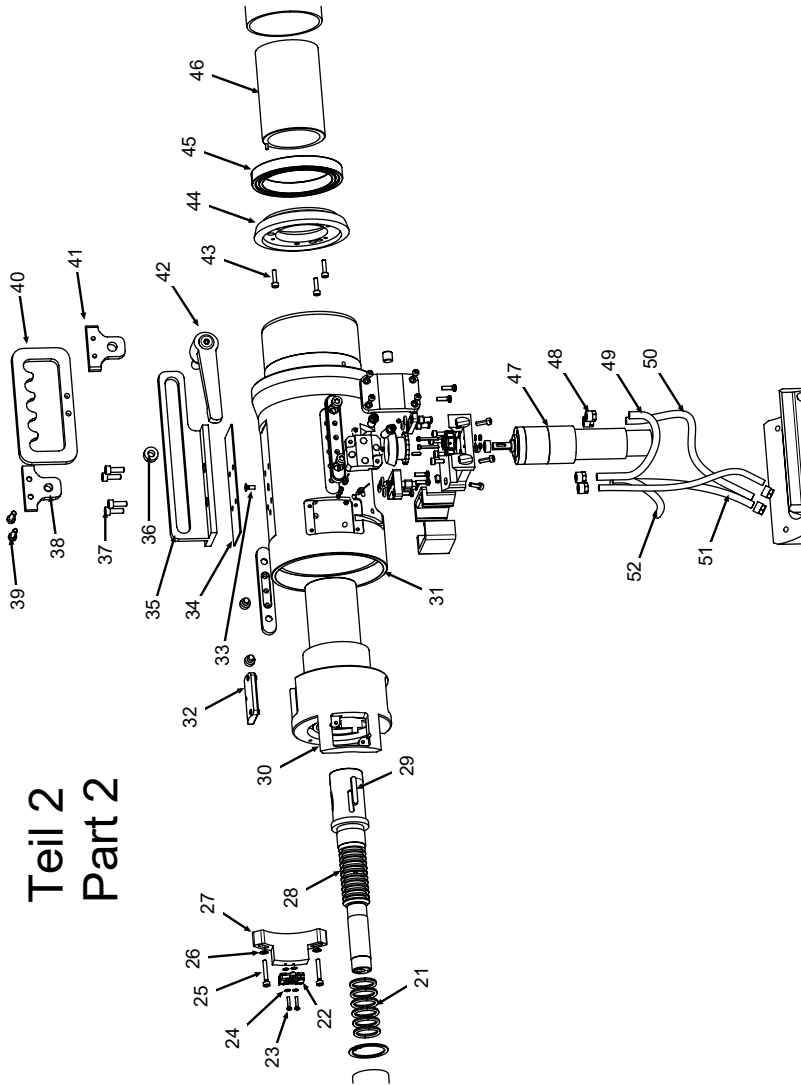

POS. NO.	CODE	STK. QTY.	BEZEICHNUNG DESCRIPTION	POS. NO.	CODE	STK. QTY.	BEZEICHNUNG DESCRIPTION
41	833 007 002	1	Blech links Sheet left	51	831 007 079	1	Wasservorlaufschlauch Water flow hose
42	790 046 194	1	Verstellbarer Klemmhebel Adjustable clamping lever	52	831 007 028	1	Wasserüberlaufschlauch Water overflow hose
43	305 501 055	3	Zylinderschraube ISO4762-M3x12-A2 Cylinder screw ISO4762-M3x12-A2				
44	831 001 113	1	Kegelrad Bevel gear				
45	831 007 065	1	Rillenkugellager SKF 61812 60x78x10 Grooved ball bearing SKF 61812 60x78x10				
46	831 050 007	1	Isolierbuchse Insulating bushing				
47	831 007 116	1	Motor/Tachoeinheit P16/P20 Motor/speedometer unit P 16/20				
48	831 001 010	6	Überwurfmutter Union nut				
49	831 007 080	1	Wasserrücklaufschlauch Water outlet hose				
50	831 007 016	1	Gasschlauch Gas hose				

Teil 3  
Part 3

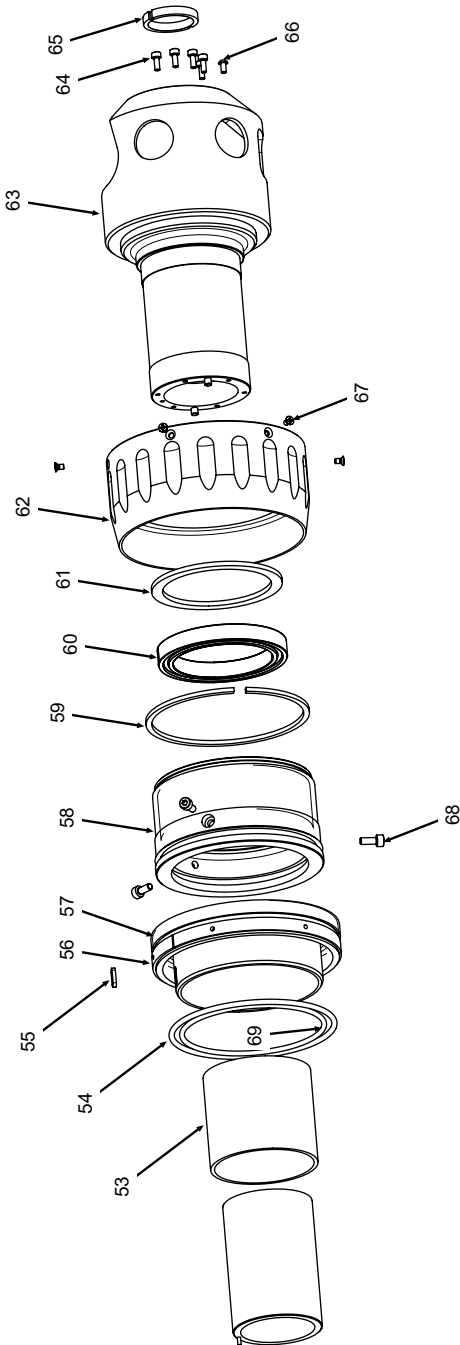

POS. NO.	CODE	STK. QTY.	BEZEICHNUNG DESCRIPTION	POS. NO.	CODE	STK. QTY.	BEZEICHNUNG DESCRIPTION
53	831 007 045	1	Distanzteil Distance part	63	831 050 008	1	Spindelaufnahmeglocke Spindle receiver cover
54	831 007 068	1	O-Ring 4375 D94.84x3.53 O-ring 4375	64	305 501 080	5	Zylinderschraube ISO4762-M3x8-A2 Cylinder screw ISO4762-M3x8-A2
55	831 007 044	1	Passfeder Feather key	65	831 007 057	1	Ring Ring
56	831 007 039	1	Ring, zweiteilig Ring, bipartite	66	305 501 065	1	Zylinderschraube ISO4762-M3x6-A2 Cylinder screw ISO4762-M3x6-A2
57	831 007 042	1	Messingnut Brass groove	67	302 000 034	6	Senkschraube ISO7046-1-M3x5-A2 Countersunk screw ISO7046-1-M3x5-A2
58	831 007 043	1	Buchse Bushing	68	305 501 067	3	Zylinderschraube ISO4762-M4x10-A2 Cylinder screw ISO4762-M4x10-A2
59	831 007 064	1	Sicherungsring WR95 Retaining ring WR95	69	831 007 067	1	O-Ring 4325 D82.14x3.53 O-ring 4325
60	831 007 065	1	Rillenkugellager SKF 61812 60x78x10 Grooved ball bearing SKF 61812 60x78x10				
61	831 007 056	1	Teflonring Teflon ring				
62	831 007 001	1	Einstellflansch Adjustment flange				

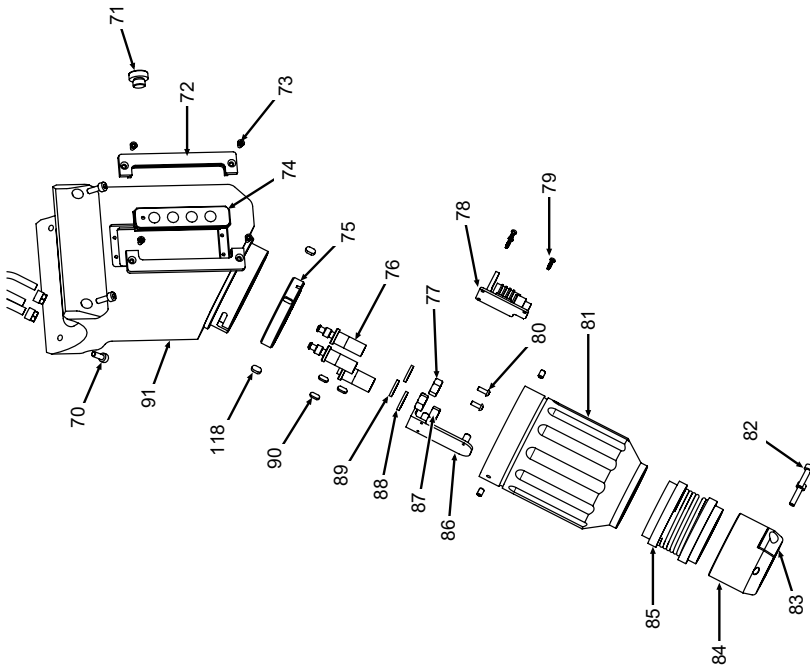

## Teil 4 Part 4

POS. NO.	CODE	STK. QTY.	BEZEICHNUNG DESCRIPTION	POS. NO.	CODE	STK. QTY.	BEZEICHNUNG DESCRIPTION
70	305 501 070	4	Zylinderschraube ISO4762-M4x12-A2 Cylinder screw ISO4762-M4x12-A2	80	307 001 114	2	Linsenschraube ISO7380-M3x8-A2 Oval-head screw ISO7380-M3x8-A2
71	831 007 060	1	Stopfen Plug	81	833 050 004	1	Ring, trichterförmig Funnel-shaped ring
72	833 007 004	2	Halterung Tastatur Clamp keyboard	82	305 501 072	2	Zylinderschraube ISO4762-M4x16-A2 Cylinder screw ISO4762-M4x16-A2
73	303 305 010	4	Senkschraube ISO14581-M3x10-TX Countersunk screw ISO14581-M3x10-TX	83	831 007 048	1	Zugentlastung Strain relief
74	812 050 006	1	Schalterplatte TP Switch plate TP	84	831 007 047	1	Zugentlastung Strain relief
75	831 007 107	1	Anschlussblock Connector block	85	831 007 025	1	Knickschutzfeder Bend protection spring
76	831 007 022	1	Wasserrücklaufnippel Water inlet nipple	86	833 007 006	1	Halterung Platine Holder board
77	831 007 036	1	Messingmutter Brass nut	87	831 007 037	2	Messingmutter Brass nut
78	812 050 009	1	Tachospannungsteiler TP 400/600/1000 voltage divider TP 400/600/1000	88	831 007 078	1	U-Scheibe D16 Washer D16
79	833 007 005	3	Linsenschraube PT 2.5x8 TX A2 Panhead screw PT 2.5x8 TX A2	89	831 007 077	2	U-Scheibe D14 U-Washer D14

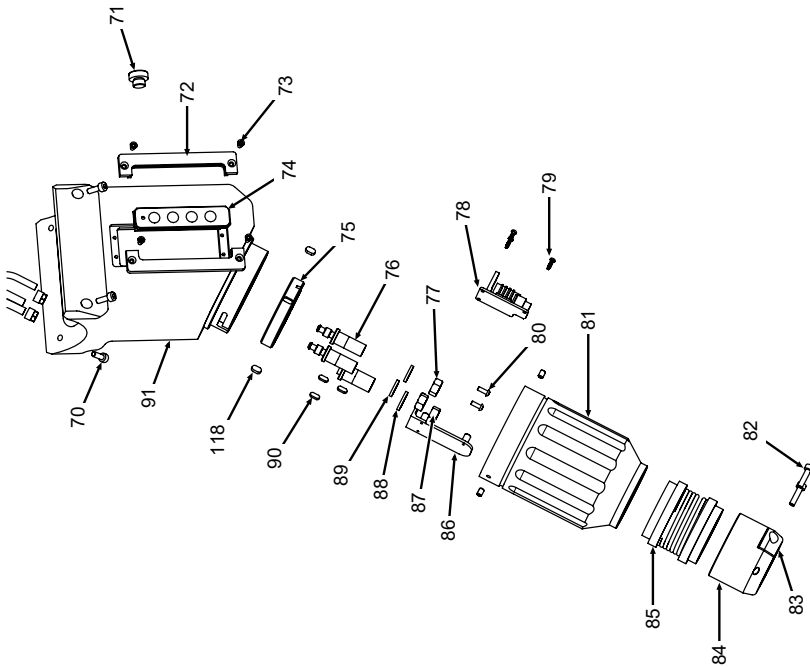

# Teil 4 Part 4



POS. NO.	CODE	STK. QTY.	BEZEICHNUNG DESCRIPTION
90	565 000 071	3	Passfeder 3x3x8 A Feather key 3x3x8 A
91	833 001 114	1	Socket Base
118	565 000 112	2	Passfeder DIN6885-A4x4x8 Fitting key DIN6885-A4x4x8

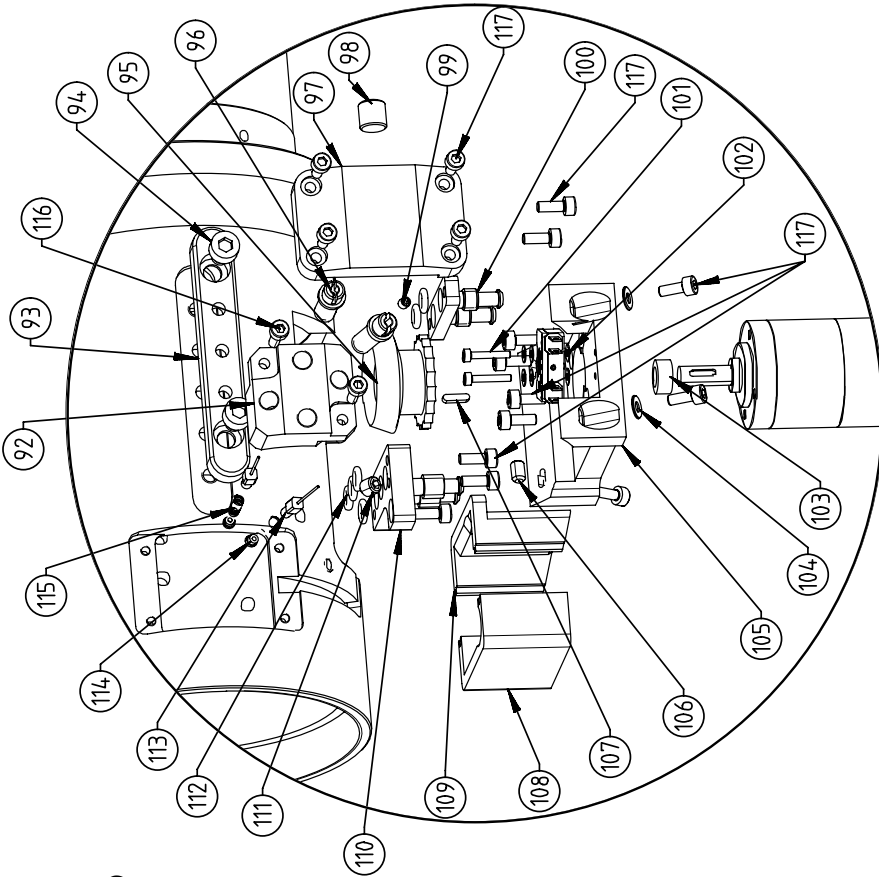

# Teil 5 Part 5

POS. NO.	CODE	STK. QTY.	BEZEICHNUNG DESCRIPTION	POS. NO.	CODE	STK. QTY.	BEZEICHNUNG DESCRIPTION
92	831 001 017	1	Kohlenbürstenbefestigung Carbon brush fixing	102	542 500 326	6	Scheibe DIN125-ISO7089-Ø2.2-A2 Washer DIN125-ISO7089-Ø2.2-A2
93	831 007 061	2	Seitenplatte Side plate	103	832 007 025	1	Unterlegscheibe Washer
94	305 501 093	4	Zylinderschraube ISO4762-M5x6-A2 Cylinder screw ISO4762-M5x6-A2	104	542 500 325	4	Scheibe DIN125-ISO7089-d3.2-A2 Washer DIN125-ISO7089-d3.2-A2
95	831 050 002	1	Kegelritzel Bevel gear	105	831 007 013	1	Rotationsmotor, Halter Rotation motor, support
96	831 007 062	2	Kohlebürstenhalter Carbon brush holder	106	445 005 227	1	Gewindestift DIN913-M4x4-A2 Grub screw DIN913-M4x4-A2
97	831 007 027	1	Deckplatte, Kohlebürsten Cover plate, carbon brushes	107	565 000 072	1	Passfeder DIN6885-A2x2x8 Fitting key DIN6885-A2x2x8
98	831 007 059	1	Stopfen Plug	108	831 007 074	1	Schutz, hinterer Block Protection rear block
99	445 005 220	2	Gewindestift DIN913-M3x3-A2 Grub screw DIN913-M3x3-A2	109	831 007 075	1	Schutz, vorderer Block Protection, front block
100	831 001 111	1	Wasseranschluss Water connection	110	831 001 108	1	Verteiler, Anschlussblock Divider, terminal block
101	305 501 050	2	Zylinderschraube ISO4762-M2x12-A2 Cylinder screw ISO4762-M2x12-A2	111	445 005 222	2	Gewindestift DIN913-M5x5-A2 Grub screw DIN913-M5x5-A2

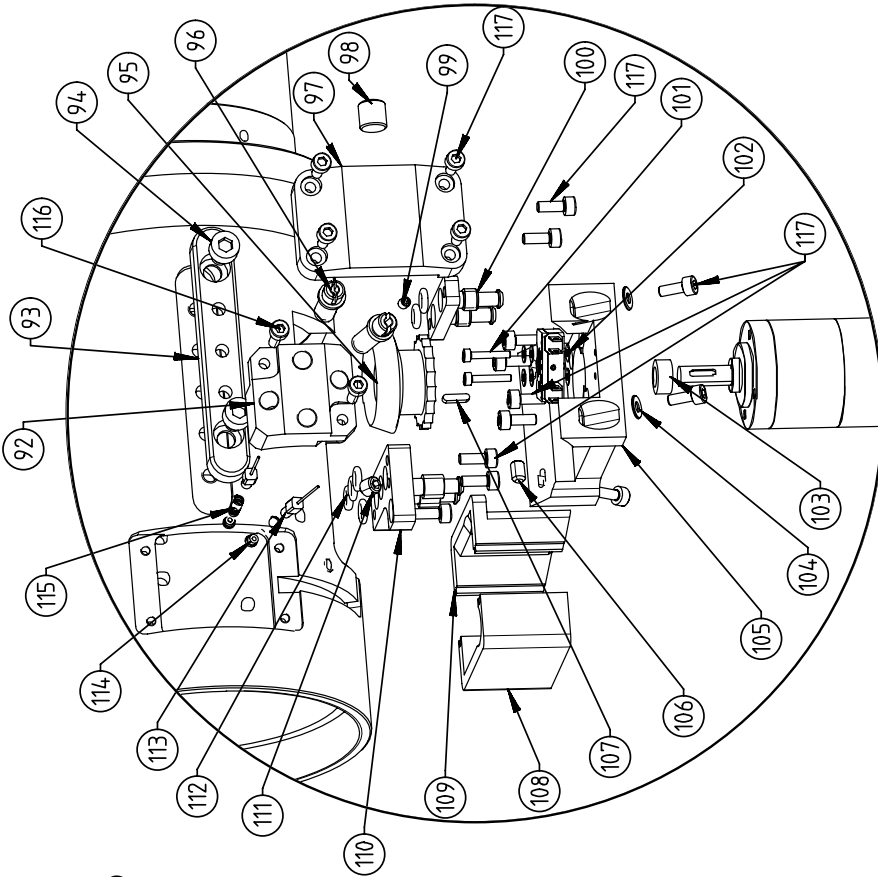

# Teil 5 Part 5

POS. NO.	CODE PART NO.	STK. QTY.	BEZEICHNUNG DESCRIPTION
112	831 001 051	6	O-Ring 3.68 x 1.78 FKM 80 O-ring 3.68 x 1.78 FKM 80
113	831 001 120	2	Kohlebürste Carbon brush
114	831 007 038	2	Feder, Führung Spring, guide
115	831 001 119	2	Kohlebürste, Feder Carbon brush, spring
116	305 501 100	2	Zylinderschraube ISO4762-M3x10-A2 Cylinder screw ISO4762-M3x10-A2
117	305 501 080	18	Zylinderschraube ISO4762-M3x8-A2-VA Cylinder screw ISO4762-M3x8-A2-VA

# 11.5 Grundkörper Übersicht P16 EVO AVC | Base body overview P16 EVO AVC

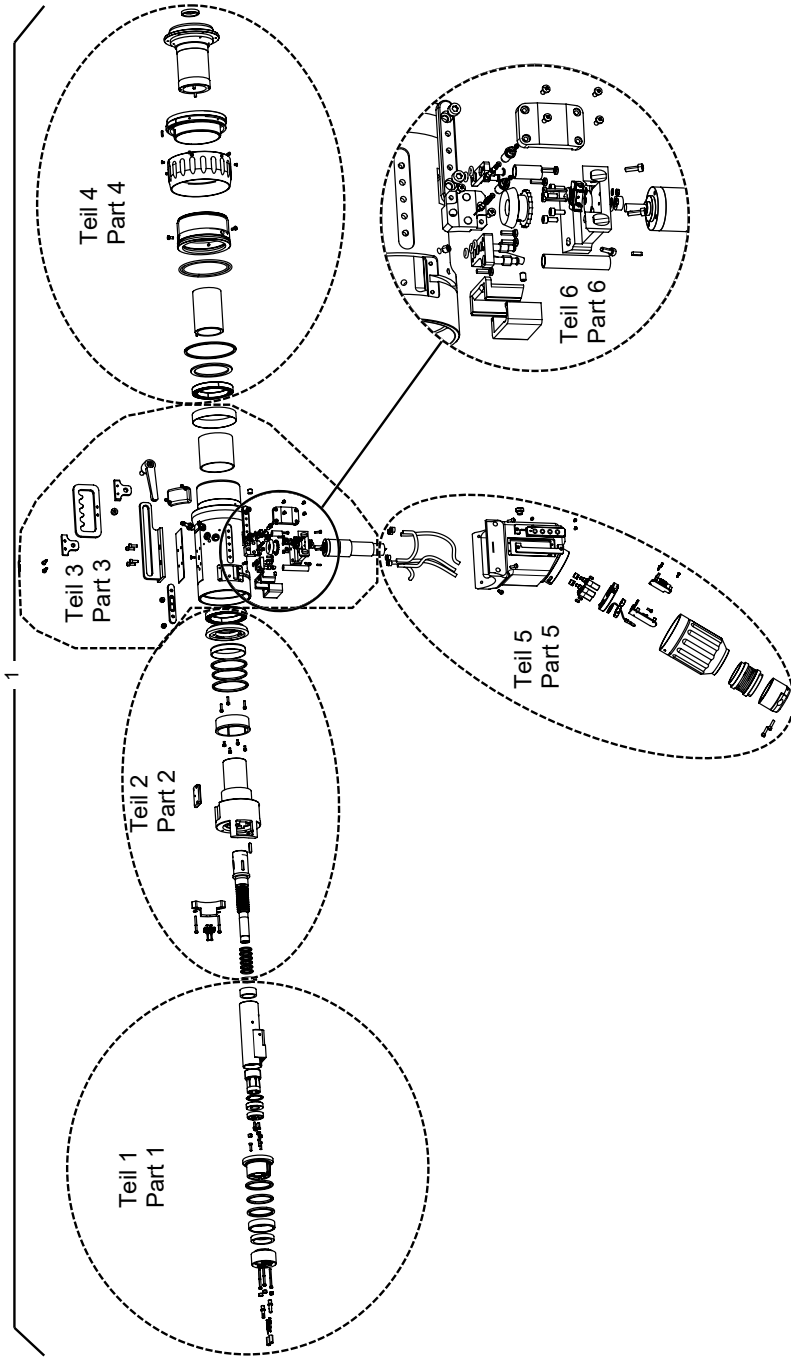

POS. NO.	CODE PART NO.	STK. QTY.	BEZEICHNUNG DESCRIPTION
1	833 050 080	1	Grundkörper Teil 1, P16 AVC EVO, kpl. Base body Part 1, P16 AVC EVO, cpl.

## 11.5.1 Grundkörper AVC | Base body AVC

### Teil 1 Part 1

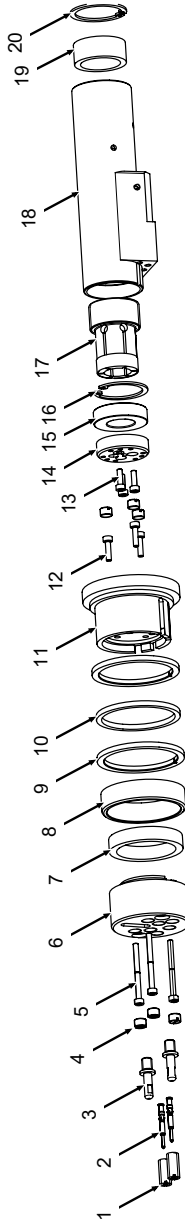



POS. NO.	CODE	STK. QTY.	BEZEICHNUNG DESCRIPTION	POS. NO.	CODE	STK. QTY.	BEZEICHNUNG DESCRIPTION
1	831 007 108	2	Messingbuchse Brass bush	11	831 007 005	1	Kollektorflansch Collector flange
2	831 007 095	2	Steckkontakt Plug contact	12	305 501 055	3	Zylinderschraube ISO4762-M3x12-A2 Cylinder screw ISO4762-M3x12-A2
3	831 007 010	2	Bolzen Bolt	13	305 501 080	13	Zylinderschraube ISO4762-M3x8-A2-VA Cylinder screw ISO4762-M3x8-A2-VA
4	848 007 033	6	Gewindestopfen Screw plug	14	831 007 009	1	Anschlagscheibe Stop washer
5	305 501 091	3	Zylinderschraube ISO4762-M3x35-A2 Cylinder screw ISO4762-M3x35-A2	15	831 007 053	1	Gleitlager Slide bearing
6	831 007 026	1	Isolierflansch Insulating flange	16	554 058 330	1	Sicherungsring DIN472-30x1.2 Circlip DIN472-30x1.2
7	831 007 073	1	Zentrierring Centerring ring	17	831 001 235	1	Graphikupplung P16/P20 Graphite clutch P16/P20
8	831 007 008	1	Isolierkollektorring Insulating collector ring	18	831 007 110	1	Messingkörper, Rotationskupplung Brass body, redation coupling
9	831 007 006	2	Kollektorring Collector ring	19	831 007 058	1	Gleitlager Slide bearing
10	831 007 007	1	Isolierkollektorring Insulating collector ring	20	554 058 332	1	Sicherungsring D32x1.2 Retaining ring D32x1,2

# Teil 2 Part 2

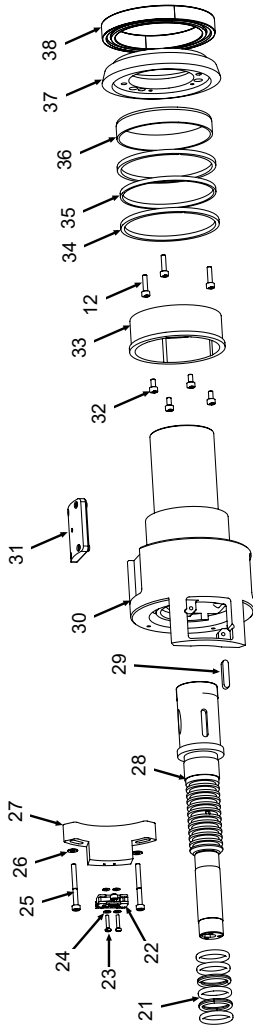

POS. NO.	CODE	STK. QTY.	BEZEICHNUNG DESCRIPTION	POS. NO.	CODE	STK. QTY.	BEZEICHNUNG DESCRIPTION
21	831 001 052	6	O-Ring PRP 116 O-ring PRP 116	31	831 007 003	1	Platte, klein Plate, small
22	831 050 100	1	Mikroschalter, komplett Microswitch, complete	32	305 501 065	4	Zylinderschraube ISO4762-M3x6-A2 Cylinder screw ISO4762-M3x6-A2
23	305 501 048	2	Zylinderschraube ISO4762-M2x16-A2 Cylinder screw ISO4762-M2x16-A2	33	831 007 102	1	Flansche Flanges
24	542 500 326	4	Scheibe D2.2 Washer D2.2	34	831 007 104	1	Kollektorring Collector ring
25	305 501 056	2	Zylinderschraube ISO4762-M3x30-A2 Cylinder screw ISO4762-M3s30-A2	35	831 007 103	1	Isolierkollektorring Insulating collector ring
26	542 500 325	2	Scheibe D3.2 Washer D3.2	36	831 007 105	1	Isolierkollektorring Insulating collector ring
27	831 007 076	1	Halterung Mikroschalter Holder microswitch	37	831 001 113	8	Kegeelrad Bevel gear
28	831 007 121	1	Achse Rotationskupplung V2 Axis rotary clutch V2	38	831 007 065	1	Rillenkugellager SKF 61812 60x78x10 Grooved ball bearing SKF 61812 60x78x10
29	565 000 119	1	Passfeder DIN6885-A4x4x20 Fitting key DIN6885-A4x4x20	12	305 501 055	3	Zylinderschraube ISO4762-M3x12-A2 Cylinder screw ISO4762-M3x12-A2
30	831 007 004		Isolierkörper Insulating body				

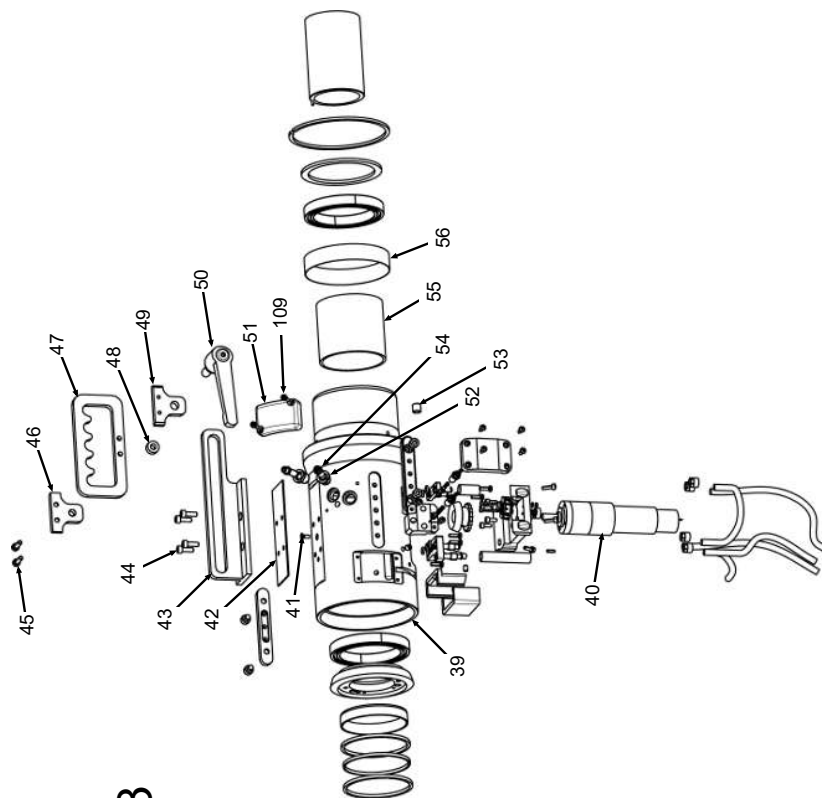

## Teil 3 Part 3

POS. NO.	CODE	STK. QTY.	BEZEICHNUNG DESCRIPTION	POS. NO.	CODE	STK. QTY.	BEZEICHNUNG DESCRIPTION
39	831 007 086	1	Maschinenkörper P16 AVC Machine body P16 AVC	50	790 046 194	1	Verstellbarer Klemmhebel Adjustable clamping lever
40	831 001 020	1	Motor/Tachoeinheit P16/P20 Motor/speedometer unit P16/20	51	831 007 100	1	Kohlebürste, Abdeckung Carbon brush, cover
41	302 301 051	1	Senkschraube ISO10642-M3x8-A2 Countersunk screw ISO10642-M3x8-A2	52	831 007 101	2	Gewindebuchse Threaded bushing
42	831 007 050	1	Filzunterlage Felt base	53	831 007 059	1	Stopfen Plug
43	833 007 003	1	Bügel Clamp	54	831 007 062	4	Kohlebürstenhalter Carbon brush holder
44	305 501 070	4	Zylinderschraube ISO4762-M4x12-A2 Cylinder screw ISO4762-M4x12-A2	55	831 007 045	1	Distanzteil Space part
45	305 501 074	2	Zylinderschraube ISO4762-M4x14-A2 Cylinder screw ISO4762-M4x14-A2	56	831 001 018	1	Teflonstreifen Teflon strip
46	833 007 001	1	Blech rechts Sheet right	109	305 501 100	2	Zylinderschraube ISO4762-M3x10-A2 Cylinder screw ISO4762-M3x10-A2
47	833 007 049	1	Aufhängung Suspension				
48	828 008 015	1	Buchse Bushing				
49	833 007 002	1	Blech links Sheet left				

# Teil 4 Part 4

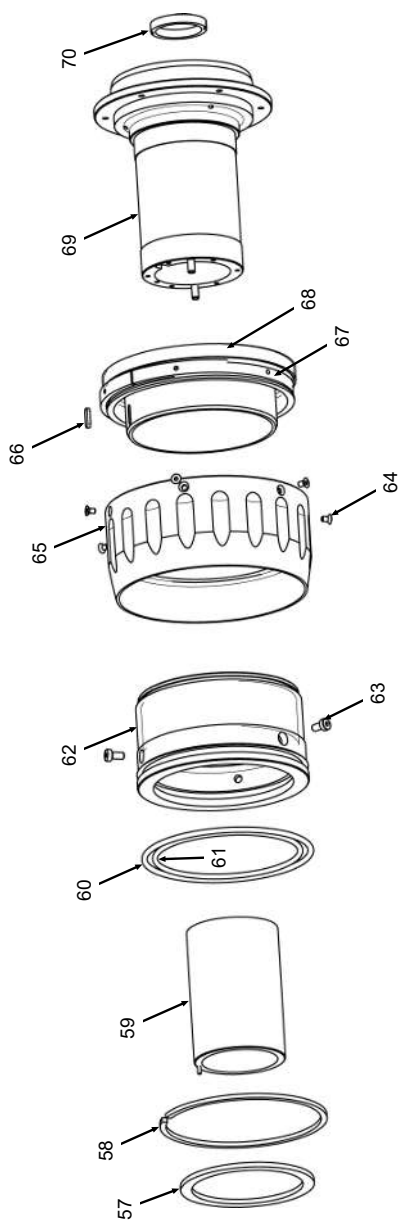

POS. NO.	CODE PART NO.	STK. QTY.	BEZEICHNUNG DESCRIPTION	POS. NO.	CODE PART NO.	STK. QTY.	BEZEICHNUNG DESCRIPTION
57	831 007 056	1	Teflonring Teflon ring	67	831 007 039	1	Ring zweiteilig Ring, two-part
58	831 007 064	1	Sicherungsring WR95 Circlip WR95	68	831 007 042	1	Messingnut Brass nut
59	831 050 007	1	Isolierbuchse Insulating bush	69	831 050 082	1	Flansch Flange
60	831 007 068	1	O-Ring 4375 D94.84x3.53 O-ring 4325 D9.84x3.53	70	831 007 057	1	Ring Ring
61	831 007 067	1	O-Ring 4325 D82.14x3.53 O-ring 4325 D82.14x3.53				
62	831 007 043	1	Buchse Bushing				
63	305 801 050	3	Zylinderschraube DIN7984-M4x8-A2 Cylinder screw DIN7984-M4x8-A2				
64	302 505 070	6	Senkschraube ISO10642-M3x5-A2 Countersunk screw ISO10642-M3x5-A2				
65	831 007 001	1	Einstellflansch Adjustable flange				
66	831 007 044	1	Passfeder Fitting key				

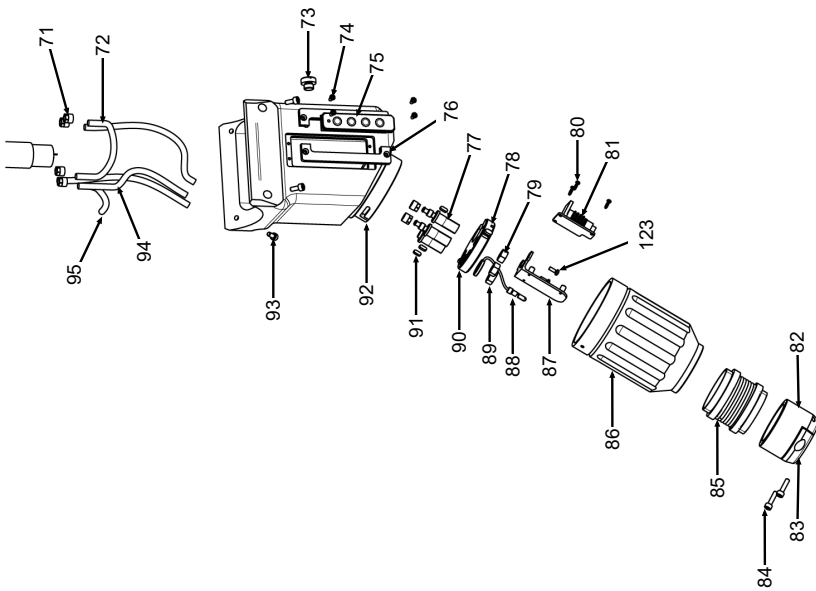

Teil 5  
Part 5



POS. NO.	CODE	STK. QTY.	BEZEICHNUNG DESCRIPTION	POS. NO.	CODE	STK. QTY.	BEZEICHNUNG DESCRIPTION
71	831 001 010	6	Überwurfmutter Union nut	81	826 012 010	1	Tachospannungsteiler, Platine Voltage divider, circuit board
72	831 001 118	1	Wasserrücklaufschlauch per Water inlet hose machine body	82	831 007 048	1	Zugentlastung Strain relief
73	831 007 060	1	Stopfen Plug	83	831 007 047	1	Zugentlastung Strain relief
74	303 305 010	4	Senkschraube ISO14581-M3x10-TX Countersunk screw ISO41581-M3x10-TX	84	305 501 072	2	Zylinderschraube ISO4762-M4x16-A2 Cylinder screw ISO4762-M4x16-A2
75	812 050 006	1	Schalterplatte TP Switch plate TP	85	831 007 025	1	Knickschutzfeder Bend protection spring
76	833 007 004	2	Halterung Tastatur Clamp keyboard	86	833 050 004	1	Ring, trichterförmig Ring, funnel-shaped
77	831 001 011	2	Gasnippel Gas nipple	87	833 007 006	1	Halterung Platine Holder board
78	565 000 112	2	Passfeder DIN6885-A4x4x8 Fitting key DIN6885-A4x4x8	88	831 050 005	1	AVC Messanschluss P16 AVC AVC measuring connection P16 AVC
79	831 007 037	2	Messingmutter Brass nut	89	831 007 036	1	Messingmutter Brass nut
80	833 007 005	3	Linsenschraube PT 2.5x8 TX A2 Panhead screw PT 2.5x8 TX A2	90	831 007 107	1	Anschlussblock Terminal block

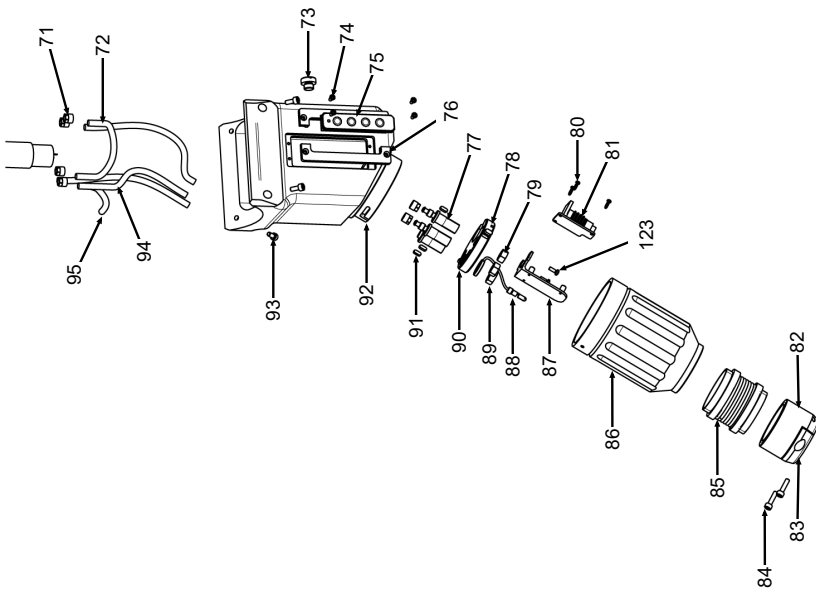

# Teil 5 Part 5

POS. NO.	CODE	STK.	BEZEICHNUNG
NO.	PART NO.	QTY.	DESCRIPTION
91	565 000 071	2	Passfeder DIN6885-A3x3x8 Fitting key DIN6885-A3x3x38
92	833 001 114	1	Sockel Base
93	305 501 067	4	Zylinderschraube ISO4762-M4x10-A2 Cylinder screw ISO4762-M4x10-A2
94	831 007 016	1	Gasschlauch Gas hose
95	831 007 028	1	Wasserüberlaufschlauch Water overflow hose
123	307 001 114	2	Linsenschraube ISO7380-M3x8-A2 Oval-head screw ISO7380-M3x8-A2

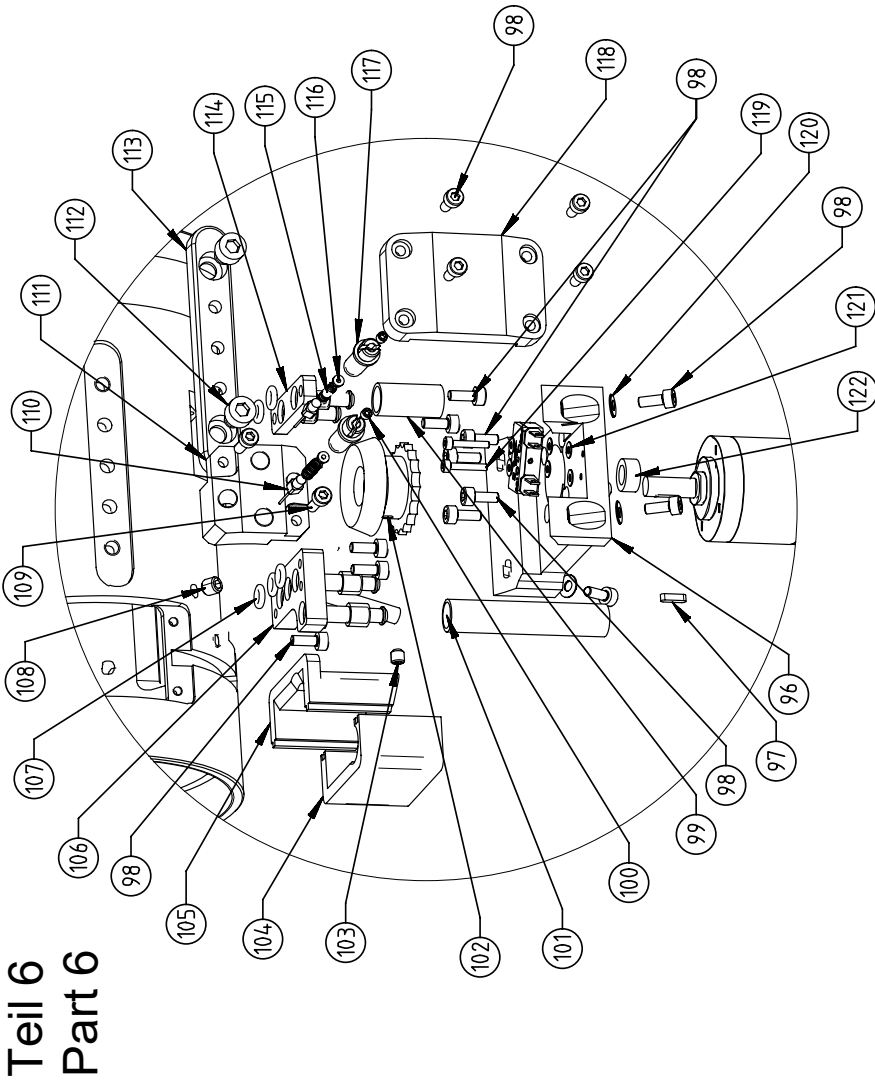

Teil 6  
Part 6

POS. NO.	CODE	STK. QTY.	BEZEICHNUNG DESCRIPTION	POS. NO.	CODE	STK. QTY.	BEZEICHNUNG DESCRIPTION
96	831 007 013	1	Rotationsmotor, Halter Rotation motor, support	106	831 001 108	1	Verteiler, Anschlussblock Divider, terminal block
97	565 000 072	1	Passfeder DIN6885-A2x2x8 Fitting key DIN6885-A2x2x8	107	831 001 051	6	O-Ring 3.68 x 1.78 FKM 80 O-ring 3.68 x 1.78 FKM 80
98	305 501 080	18	Zylinderschraube ISO4762-M3x8-A2-VA Cylinder screw ISO4762-M3x8-A2-VA	108	445 005 222	2	Gewindestift DIN913-M5x5-A2 Grub screw DIN913-M5x5-A2
99	831 001 110	2	Isolierhülse AD10 ID8 L20 Insulating sleeve OD10 ID8 L20	109	305 501 100	2	Zylinderschraube ISO4762-M3x10-A2 Cylinder screw ISO4762-M3x10-A2
100	445 005 220	2	Gewindestift DIN913-M3x3-A2 Threaded pin DIN913-M3x3-A2	110	831 001 120	2	Kohlebürste Carbon brush
101	831 007 097	1	Isolierhülse AD10 ID8 L50 Insulating sleeve OD10 ID8 L50	111	831 001 017	1	Kohlenbürstenbefestigung Carbon brush fixing
102	831 050 002	1	Kegelritzel Bevel gear	112	305 501 093	14	Zylinderschraube ISO4762-M5x6-A2 Cylinder screw ISO4762-M5x6-A2
103	445 005 227	1	Gewindestift DIN913-M4x4-A2 Grub screw DIN913-M4x4-A2	113	831 007 061	2	Seitenplatte Side plate
104	831 007 074	1	Schutz, hinterer Block Protection rear block	114	831 001 111	1	Wasseranschluss Water connection
105	831 007 075	1	Schutz, vorderer Block Protection, front block	115	831 001 119	2	Kohlebürste, Feder Carbon brush, spring

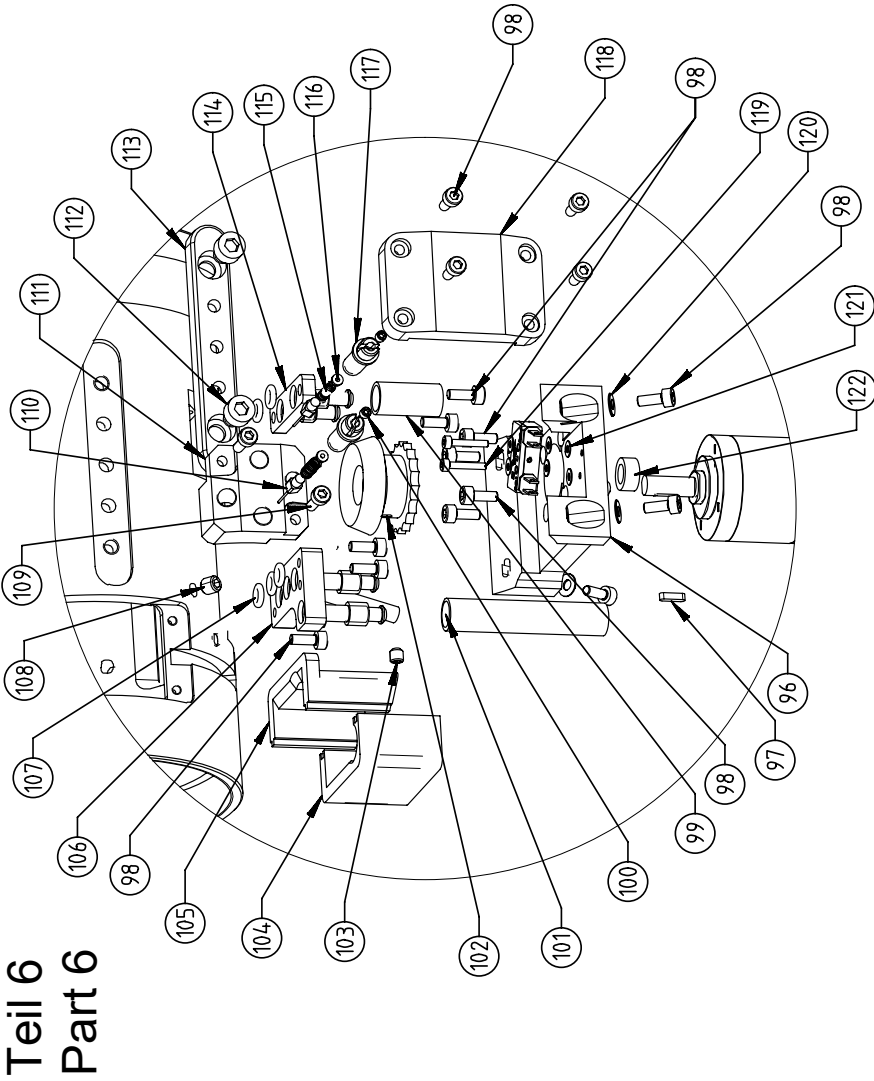

Teil 6  
Part 6

POS. NO.	CODE	STK. QTY.	BEZEICHNUNG DESCRIPTION
116	831 007 038	2	Feder, Führung Spring, guide
117	831 007 062	2	Kohlebürstenhalter Carbon brush holder
118	831 007 027	1	Deckplatte, Kohlebürsten Cover plate, carbon brushes
119	305 501 050	2	Zylinderschraube ISO4762-M2x12-A2 Cylinder screw ISO4762-M2x12-A2
120	542 500 325	4	Scheibe DIN125-ISO7089-d3.2-A2 Washer DIN125-ISO7089-d3.2-A2
121	542 500 326	6	Scheibe D2.2 Washer D2.2
122	832 007 025	1	Unterlegscheibe Washer

## 11.6 Brennergruppe P16 EVO | Burner assembly P16 EVO

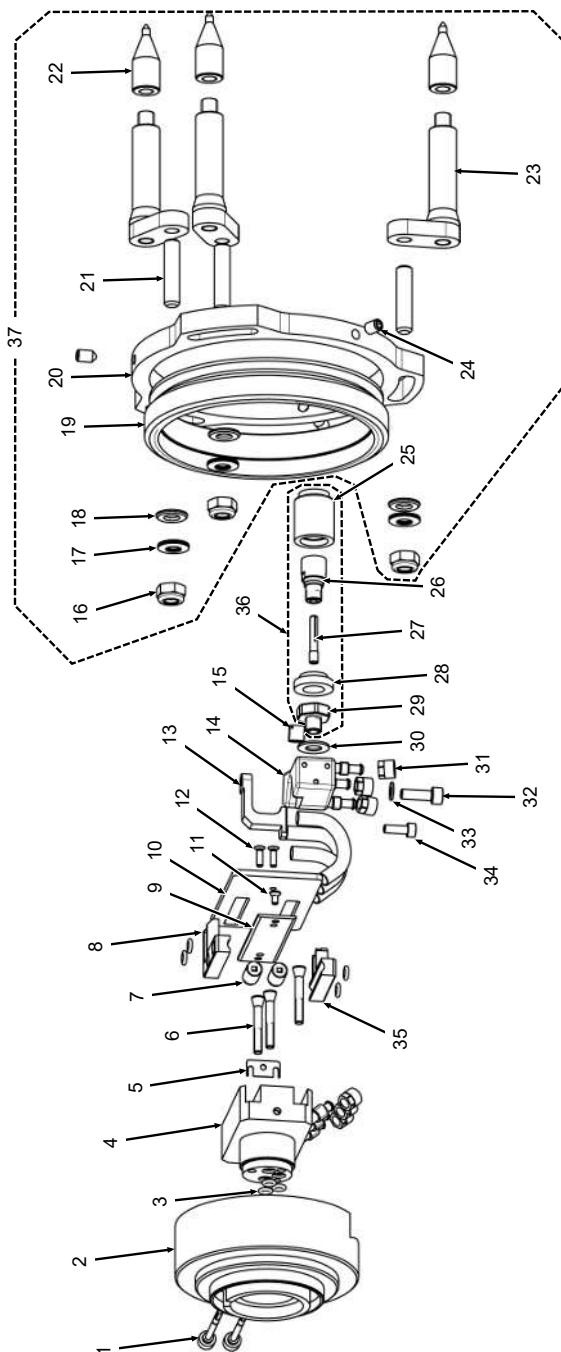



POS. NO.	CODE PART NO.	STK. QTY.	BEZEICHNUNG DESCRIPTION	POS. NO.	CODE PART NO.	STK. QTY.	BEZEICHNUNG DESCRIPTION
1	833 001 008	2	Verstellwelle P16 EVO Adjustment shaft P16 EVO	11	302 301 050	2	Senkschraube ISO10642-M3x6-A2 Countersunk screw ISO10642-M3x6-A2
2	833 013 126	1	Isolierkörper Insulator	12	302 000 074	2	Senkschraube ISO10642-M3x10-A2 Countersunk screw ISO10642-M3x10-A2
3	831 001 051	7	O-Ring 3.68x1.79 FKM 80 O-ring 3.68x1.79 FKM 80	13	831 001 014	1	Brennerhalter, Schlitten P16 Burner holder, slide P16
4	831 001 139	1	Schlittenkörper P16 Sled body P16	14	831 001 107	1	Brennerkörper P16 Torch body P16
5	831 001 234	1	Sicherungsblech Sled body P16	15	831 001 160	1	Stopfen Plug
6	831 001 167	3	Schraube, Schlitten Screw, Slide	16	501 607 312	3	Sechskantmutter ISO10511-M8-05-ZN Hexagon screw IS10511-M8-05-ZN
7	831 001 009	2	Brennerverstellerschraube Torch adjustment screw	17	790 048 210	9	Tellerfeder 15.88x8.05x0.56 Plate spring 15.88x8.05x0.56
8	831 001 013	1	Schlitten Radialverstellung 1 Slide radial adjustment 1	18	542 500 321	3	Scheibe DIN125-ISO7089-d8.4-A2 Washer DIN125-ISO7089-d8.4-A2
9	831 013 128	1	Platte, klein Plate, small	19	831 013 027	1	Halterung Holding
10	831 001 165	1	Isolierplatte Insulating plate	20	831 013 026	1	Ring, verstellbar Ring, adjustable

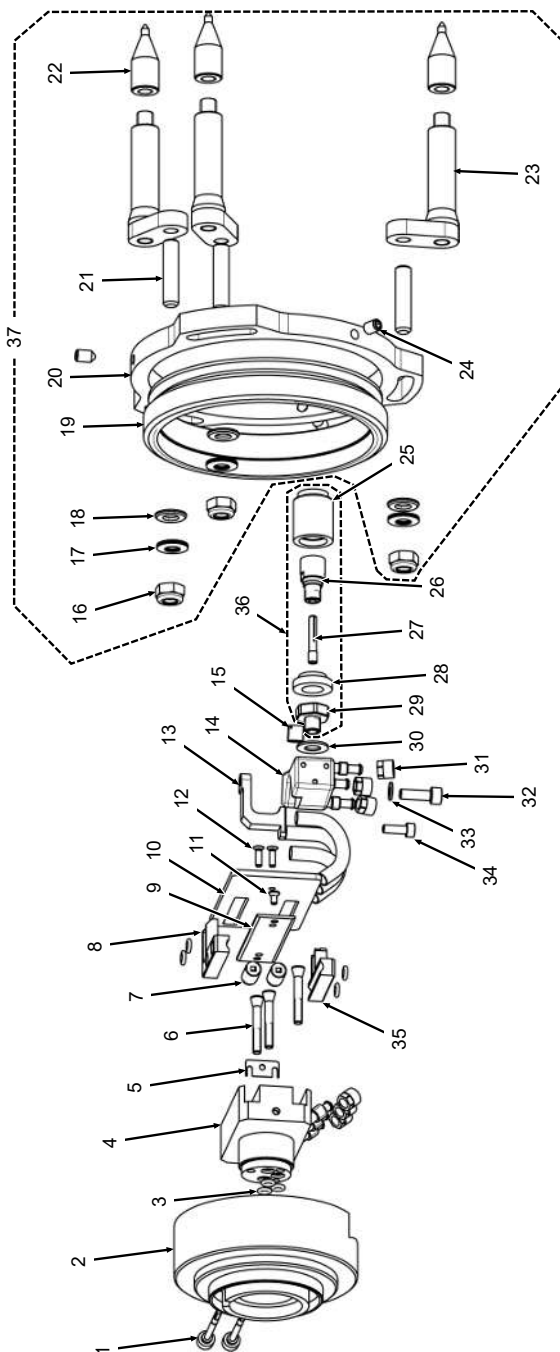

POS. NO.	CODE PART NO.	STK. QTY.	BEZEICHNUNG DESCRIPTION	POS. NO.	CODE PART NO.	STK. QTY.	BEZEICHNUNG DESCRIPTION
21	445 005 246	3	Gewindestift DIN913-M8x35-A2 Threaded pin DIN913-M8x25-A2	31	831 001 010	6	Überwurfmutter Union nut
22	833 013 023	3	Fußspitze Foot top	32	305 501 068	1	Zylinderschraube ISO4762-M5x16-A2 Cylinder screw ISO4762-M5x16-A2
23	831 050 039	3	Fuß, komplett Foot, complete	33	542 500 318	1	Scheibe DIN125-ISO7089-d4.3-A2 Washer DIN125-ISO7089-d4.3-A2
24	445 005 225	3	Gewindestift DIN913-M6x10-A2 Threaded pin DIN913-M6x10-A2	34	305 501 070	1	Zylinderschraube ISO4762-M4x12-A2 Cylinder screw ISO4762-M4x12-A2
25	831 001 060	1	Gasdüse P16/P16AVC/P20 Gas nozzle P16/P16AVC/P20	35	831 001 132	1	Radialverstellung, Schlitzen 2 Radial adjustment, slide 2
26	831 001 161	1	Gaslinse E 2.4 mm P16/P16AVC/P20 Gas lens Gas lens E 2.4 mm P16/P16AVC/P20	36	831 050 019	1	Schnellwechselladadapter Brennerausstattung Quick-change adapter torch equipment
27	831 001 058	1	Spannhülse ID2.4mm P16/P20 Gas lens P16/P16AVC/P20	37	833 002 001	1	Dreipunktauflage P16 EVO Three-point support P16 EVO
28	831 001 007	1	Brennersoliator P16/P16AVC/P20 Torch seal P16/P16AVC/P20				
29	831 030 010	1	Schnellwechselladadapter, Brenner Quick change adapter, torch				
30	833 007 007	1	Scheibe PTFE Washer PTFE				

# 11.7 Brennergruppe P16 EVO AVC | Burner assembly P16 EVO AVC

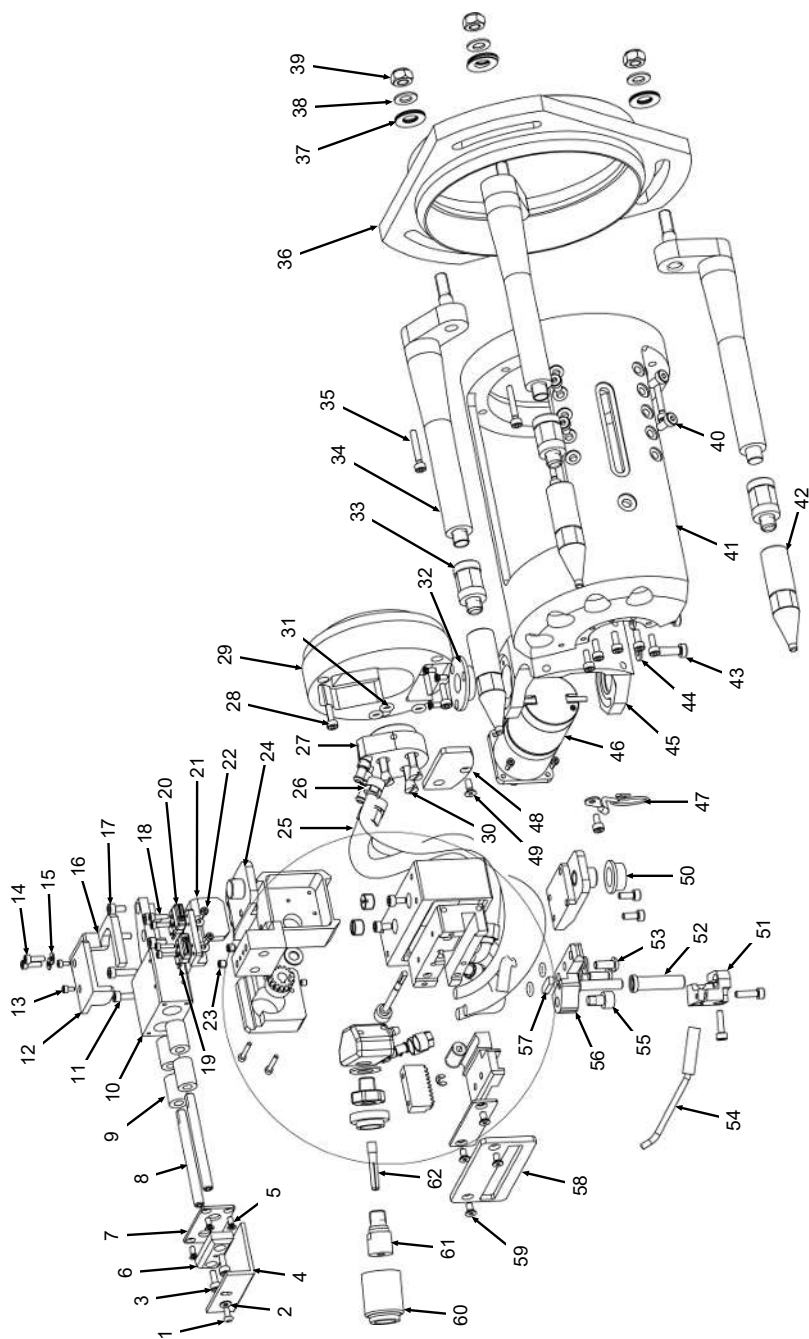

POS. NO.	CODE PART NO.	STK. QTY.	BEZEICHNUNG DESCRIPTION	POS. NO.	CODE PART NO.	STK. QTY.	BEZEICHNUNG DESCRIPTION
1	307 001 075	1	Linsenschraube ISO7380-M2.5x6-A2 Oval-head screw ISO7380-M2.5x6-A2	11	305 501 055	4	Zylinderschraube ISO4762-M3x12-A2 Cylinder screw ISO4762-M3x12-A2
2	542 500 322	3	Scheibe DIN125-ISO7089-d2.5-A2 Scheibe DIN125-ISO7089-d2.5-A2	12	831 013 070	1	Sicherung Protection
3	305 501 080	2	Zylinderschraube ISO4762-M3x8-A2-VA Cylinder screw ISO4762-M3x8-A2-VA	13	305 501 081	2	Zylinderschraube ISO4762-M2x4-A2 Cylinder screw ISO4762-M2x4-A2
4	831 013 103	1	Platte, klein Plate, small	14	305 501 054	2	Zylinderschraube ISO4762-M2.5x8-A2 Cylinder screw ISO4762-M2.5x8-A2
5	302 000 033	7	Senkschraube ISO7046-1-M2.5x6-A2 Countersunk screw ISO7046-1-M2.5x6-A2	15	542 500 323	2	Scheibe DIN125-ISO7089-d2.7-A2 Scheibe DIN125-ISO7089-d2.7-A2
6	831 013 050	1	Platte, klein Plate, small	16	831 013 072	1	Endlauf Stroke limit
7	831 013 051	1	Deckel Cover	17	305 501 065	7	Zylinderschraube ISO4762-M3x6-A2 Cylinder screw ISO4762-M3x6-A2
8	831 013 049	2	Stift Pin	18	305 501 082	4	Zylinderschraube ISO4762-M2x8-A2 Cylinder screw ISO4762-M2x8-A2
9	831 013 093	4	Kugellager 5x10x15 Ball bearing 5x10x15	19	812 012 052	2	Diode 1N4007 Diode 1N4007
10	831 013 038	1	AVC Schlitten AVC slide	20	831 001 057	2	Mikroschalter AVC/OSC Microswitch AVC/OSC

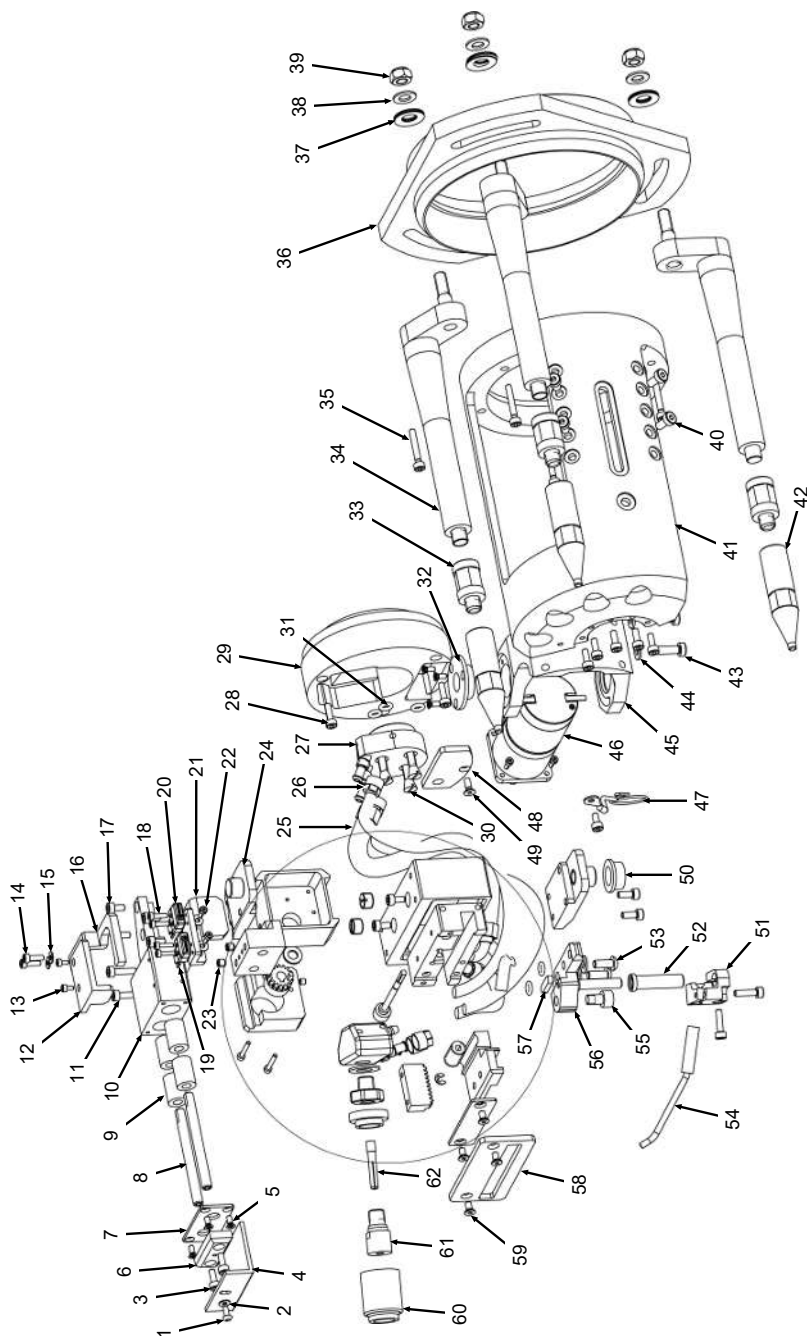

POS. NO.	CODE PART NO.	STK. QTY.	BEZEICHNUNG DESCRIPTION	POS. NO.	CODE PART NO.	STK. QTY.	BEZEICHNUNG DESCRIPTION
21	831 013 075	1	Mikroschalter, Basis Microswitch, base	31	831 001 051	5	O-Ring 3.68 x 1.78 FKM 80 O-ring 3.68x1.79 FKM 80
22	305 501 087	6	Zylinderschraube ISO4762-M2x6-A2 Cylinder screw ISO4762-M2x6-A2	32	831 013 066	1	Buchse Bushing
23	445 005 227	2	Gewindestift DIN913-M4x4-A2 Threaded pin DIN913-M4x4-A2	33	831 013 076	3	Fuß, klein Foot, small
24	831 050 092	2	Seitenführung Lateral guide	34	831 050 087	3	Fuß, Basis Foot, base
25	831 050 089	1	Strom-/Wasserkabel Current/water cable	35	305 501 058	5	Zylinderschraube ISO4762-M3x20-A2 Cylinder screw ISO4762-M3x20-A2
26	831 001 010	6	Überwurfmutter Union nut	36	831 013 042	1	Flansche, Halterung, Fuß, klein Flange holder, foot, small
27	831 050 091	1	Verteilerblock Distribution block	37	790 048 210	9	Tellerfeder 15.88x8.05x0.56 Cup spring 15.88x8.05x0.56
28	305 501 100	3	Zylinderschraube ISO4762-M3x10-A2 Cylinder screw ISO4762-M3x10-A2	38	542 500 320	3	Scheibe DIN125-ISO7089-d6.4-A2 Scheibe DIN125-ISO7089-d6.4-A2
29	831 013 060	1	Flansch Flange	39	501 607 311	3	Sechskantmutter ISO10511-M6-05-Z Hexagon nut ISO10511-M6-05-ZN
30	831 013 078	3	Schliffenschraube Slide screw	40	305 801 050	4	Zylinderschraube DIN7984-M4x8-A2 Cylinder screw ISO4762-M4x8-A2

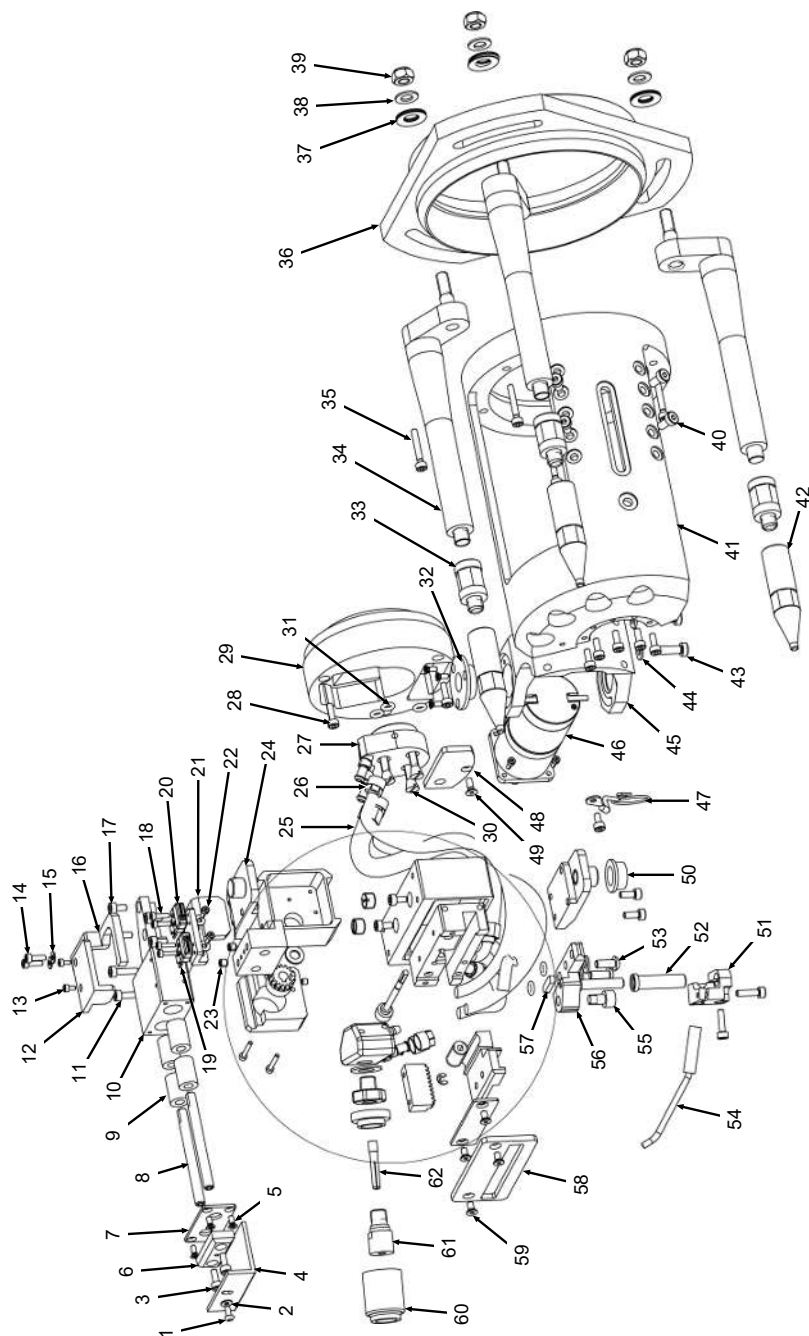



POS. NO.	CODE PART NO.	STK. QTY.	BEZEICHUNG DESCRIPTION	POS. NO.	CODE PART NO.	STK. QTY.	BEZEICHUNG DESCRIPTION
41	831 013 071	1	Glocke Bell	51	831 013 112	1	Drahtdüse, Halterung Wire nozzle, holder
42	833 013 067	3	Fuß Foot	52	831 013 087	1	Isolierbuchse Insulating bush
43	305 801 052	2	Zylinderschraube DIN7984-M4x16-A2 Cylinder screw ISO4762-M4x16-A2	53	307 001 112	2	Linsenschraube ISO7380-M4x10-A2 Oval-head screw ISO7380-M4x10-A2
44	542 500 318	4	Scheibe DIN125-ISO7089-d4.3-A2 Scheibe DIN125-ISO7089-d4.3-A2	54	831 018 051	1	Drahtdüse Wire nozzle
45	831 013 134	1	Getriebemotor, Halterung Gear motor, support	55	305 501 096	1	Zylinderschraube ISO4762-M5x8-A2 Cylinder screw ISO4762-M5x8-A2
46	831 013 063	1	Motor AVC P16 Motor AVC P16	56	831 050 084	1	Brennerhalter Torch support
47	811 050 011	1	HF-Spirale ID18 mm/L75mm P16 AVC/ KD3-100 HF spiral ID18mm/L75mm P16 AVC/ KD3-100	57	831 013 083	1	Platte, klein Plate, small
48	831 013 068	1	Deckel Cover	58	831 013 034	1	Isolierplatte, klein Insulation plate, small
49	302 301 051	1	Senkschraube ISO10642-M3x8-A2 Countersunk screw ISO10642-M3x8-A2	59	302 301 050	4	Senkschraube ISO10642-M3x6-A2 Countersunk screw ISO10642-M3x6-A2
50	831 013 069	1	Buchse Bushing	60	831 001 161	1	Gaslinse 2.4, P16/P16 AVC/P20 Gas lens P16/P16 AVC/P20

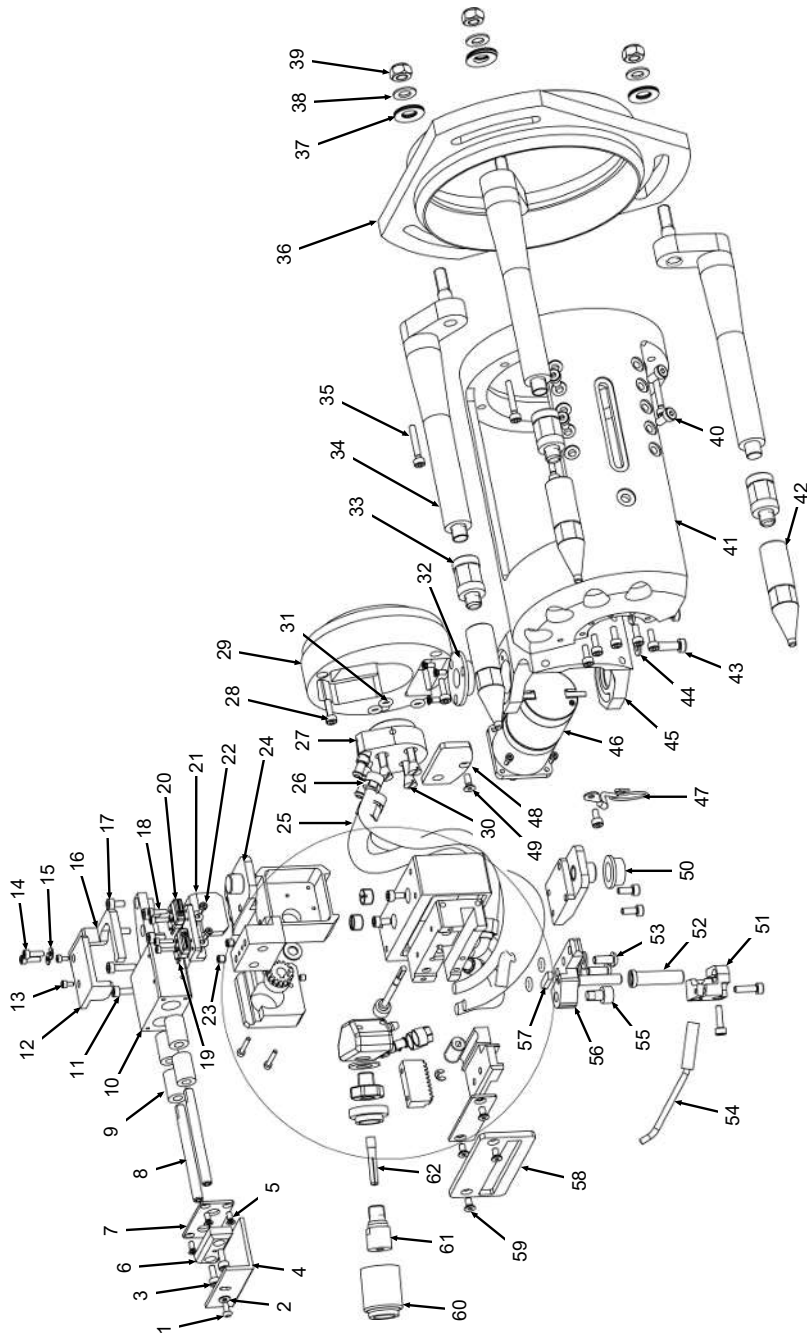

POS. NO.	CODE PART NO.	STK. QTY.	BEZEICHNUNG DESCRIPTION
61	831 001 058	1	Spannhülse ID2.4 mm P16/P20 Clamping sleeve ID2.4mm P16/P20
62	831 001 060	1	Gasdüse, P16/P16 AVC/P20 Gas lens P16/P16 AVC/P20

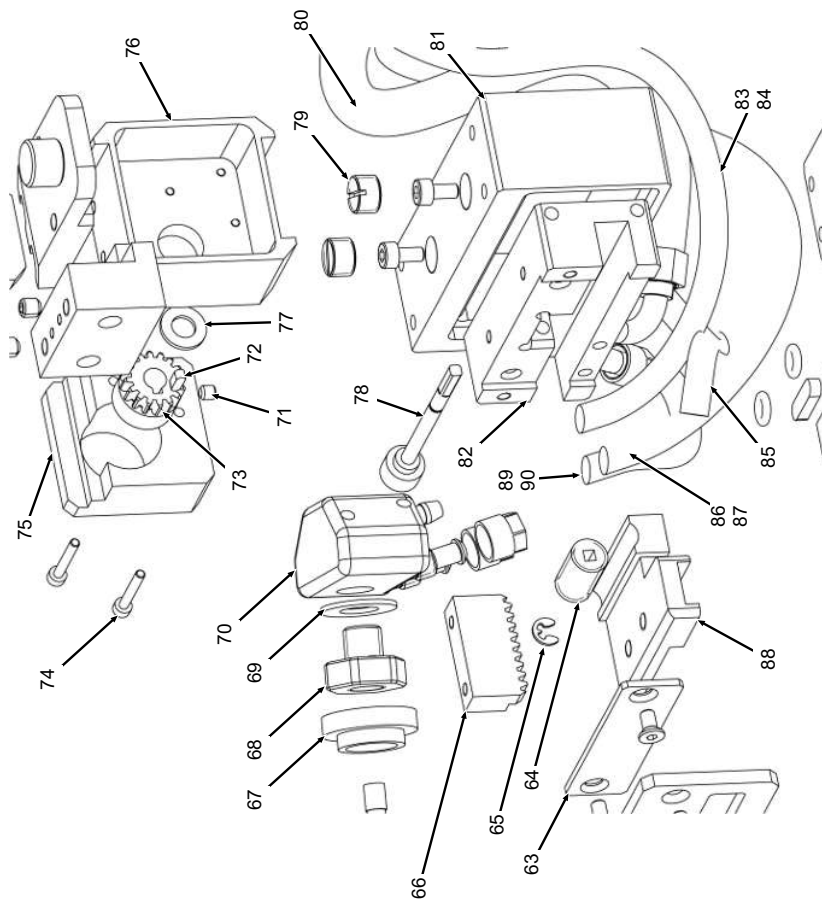

POS. NO.	CODE PART NO.	STK. QTY.	BEZEICHNUNG DESCRIPTION	POS. NO.	CODE PART NO.	STK. QTY.	BEZEICHNUNG DESCRIPTION
63	831013043	1	Platte, klein Plate, small	73	831050086	1	Kegelezahnrad, Motor Bevel gear wheel, motor
64	831001009	1	Brennervertellschraube Torch adjustment screw	74	305501049	2	Zylinderschraube ISO4762-M2x14-A2 Cylinder screw ISO4762-M2s14-A2
65	831001045	1	Sicherungsring DIN6799 2.3 Circlip DIN6799 2.3	75	831013094	1	Deckel Cover
66	831013047	1	Zahnstange Gear rack	76	831013035	1	Motorflansch Motor flange
67	831001007	1	Brennrisolator P16/P16 AVC/P20 Torch seal P16/P16 AVC/P20	77	831013084	1	Scheibe Washer
68	831030010	1	Schnellwechselladadapter, Brenner Quick change adapter, torch	78	833001008	1	Verstellwelle P16 Adjustment shaft P16
69	833007007	1	Scheibe PTFE Washer PTFE	79	831013052	2	Stopfen Plug
70	831050085	1	Brennerkörper P16 AVC Torch body P16 AVC	80	831050099	1	Schlauch, hitzebeständig 140 mm Hose, heat resistant 140 mm
71	445005220	1	Gewindestift DIN913-M3x3-A2 Threaded pin DIN913-M3x3-A2	81	833013048	1	Isolierkörper Insulating body
72	831013081	1	Passfeder DIN6885-A2x2x6 Fitting key DIN6885-A2x2x6	82	831050088	1	Schlittenkörper Slide body

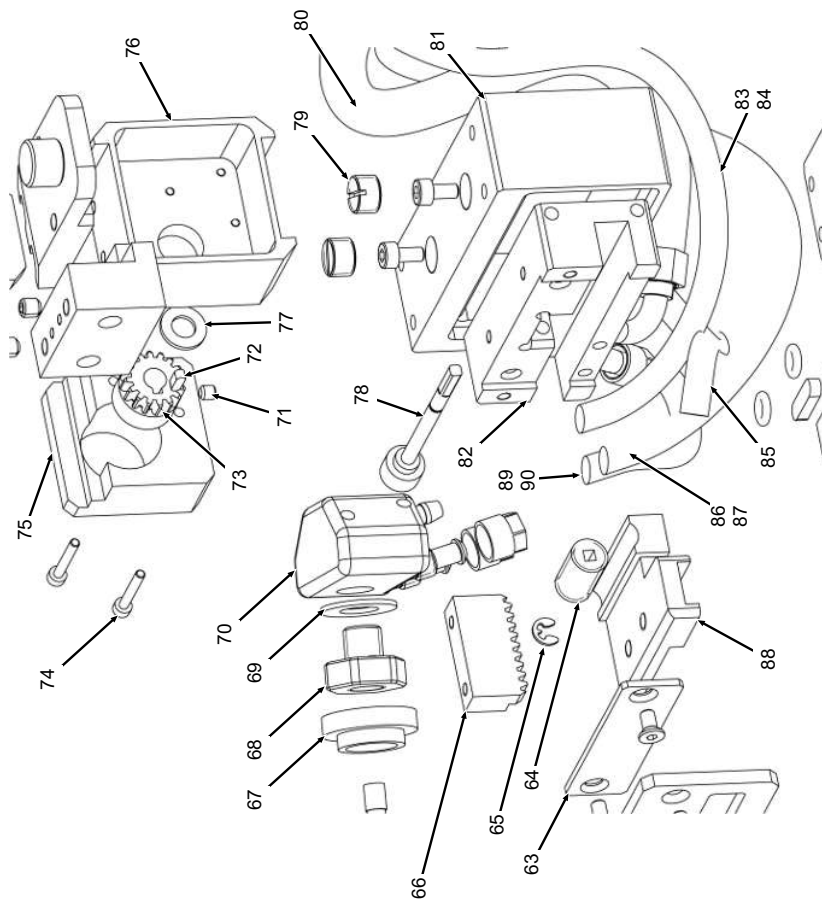

POS. NO.	CODE	STK. QTY.	BEZEICHNUNG DESCRIPTION
83	831013074	1	Gasschlauch Gas hose
84	831013110	1	Schlauch, hitzebeständig 190 mm Hose, heat resistant 190 mm
85	831001028	1	Drahtführungsschlauch L450 Wire guide hose L450
86	831013073	1	Wasservorlaufschlauch Water outlet hose
87	831013111	1	Schlauch, hitzebeständig 200 mm Hose, heat resistant 200 mm
88	831013031	1	Brennerhalter, Schlitten Torch support, slide
89	831013046	1	Wasserschlauch Water hose
90	831050098	1	Schlauch, hitzebeständig 110 mm Hose, heat resistant 100 mm

# 11.8 Kaltdrahtzuführung P16-/P16 EVO AVC | Cold wire feed P16-/P16 EVO AVC

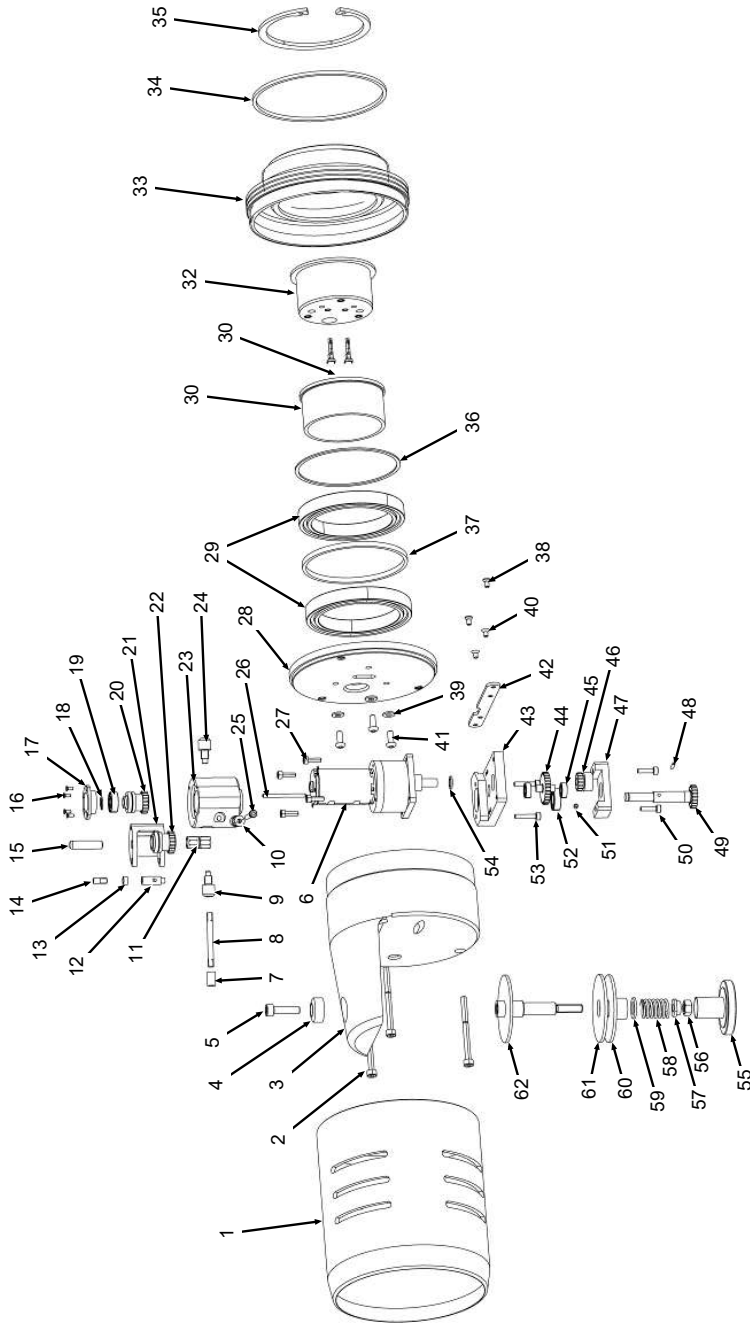



POS. NO.	CODE PART NO.	STK. QTY.	BEZEICHNUNG DESCRIPTION	POS. NO.	CODE PART NO.	STK. QTY.	BEZEICHNUNG DESCRIPTION
1	831 018 004	1	Schutzkäfig für Drahtrolle P16 Protective cage for wire roll P16	11	831 018 037	2	Rollenlager K6x9x8TN Roller bearing K6x9x8TN
2	305 501 092	3	Zylinderschraube ISO4726-M4x50-A2 Cylinder screw ISO4762-M4x50-A2	12	831 018 015	1	Gewindestift Threaded pin
3	831 018 050	1	Spulenhalterung Coil holder	13	831 018 016	1	Distanzscheibe Spacer washer
4	831 018 032	1	Buchse Bushing	14	831 018 017	1	Stift Pin
5	305 501 057	1	Zylinderschraube ISO4726-M5x20-A2 Cylinder screw ISO4762-M5x20-A2	15	565 808 421	1	Zylinderstift ISO8734-6x24-A-ST Cylinder pin ISO8734-6x24-A-ST
6	831 001 122	1	Motor, Kaltdraht P16/P20 Motor, cold wire P16/P20	16	305 501 014	3	Senkschraube ISO14581-M2x5-A2-TX Countersunk screw ISO14581-M2x5-A2-TX
7	831 001 123	1	Drahthülle, hinten Wire bushing, rear	17	831 018 014	1	Buchse Bushing
8	831 001 015	1	Drahtschlauch, hinten Wire hose, rear	18	554 158 306	1	Sicherungsring 6x0.7 Retaining ring 6x0.7
9	831 001 127	1	Drahttrittsdüse P16, Draht 0.8mm Wire entry nozzle P16, wire 0.8mm	19	831 001 050	1	Kugellager (6x15x54mm) Ball bearing (6x15x54mm)
10	831 018 054	5	Tellerfeder D8x3.2x0.45 Cup spring D8x3.2x0.45	20	831 001 125	1	Drahtförderrolle P-Antrieb (0.6-0.8mm) Wire feeding roll P-drive (0.6-0.8mm)

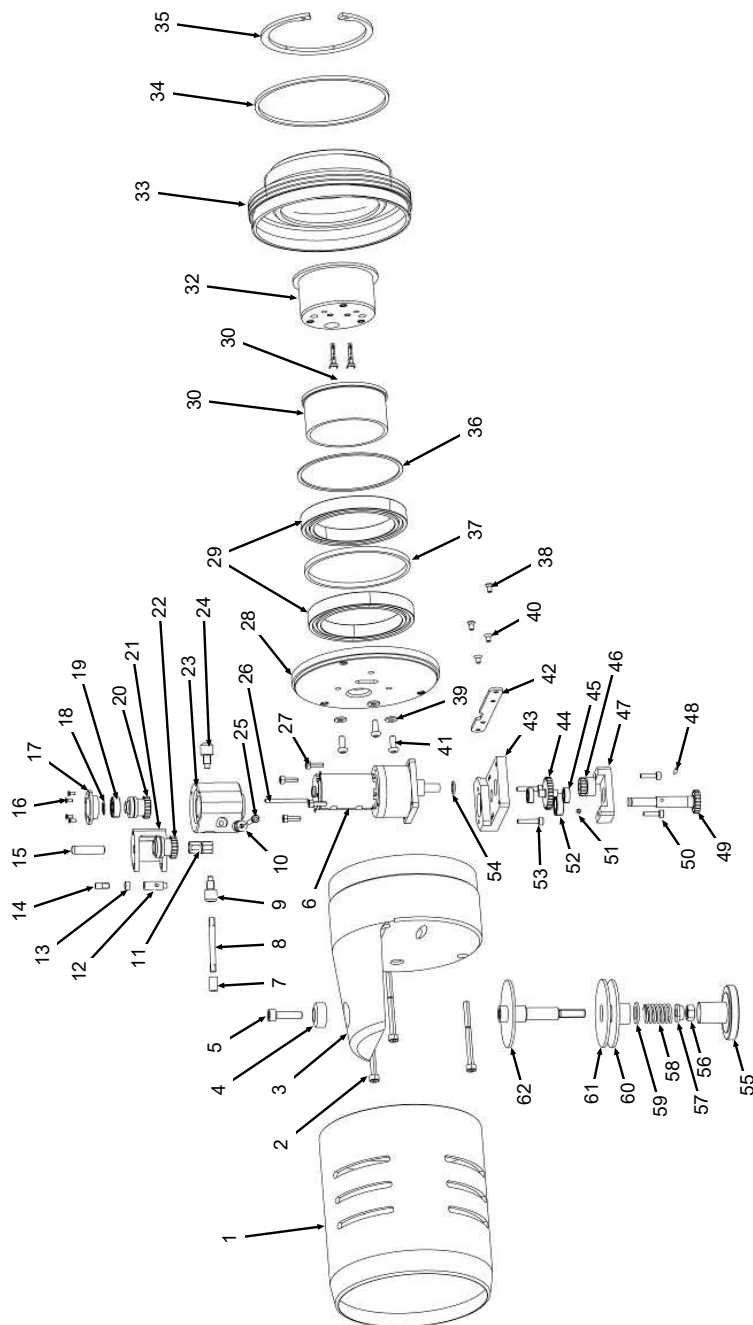

POS. NO.	CODE PART NO.	STK. QTY.	BEZEICHNUNG DESCRIPTION	POS. NO.	CODE PART NO.	STK. QTY.	BEZEICHNUNG DESCRIPTION
21	831 018 052	1	Bügel Bracket	31	831 018 033	2	Steckkontakt weiblich Pluc contact female
22	831 001 124	1	Drahtrolle (0.6-0.8mm) Wire coil (0.6-0.8mm)	32	831 050 012	1	KD-Kontaktbuchse, komplett KD contact jack, complete
23	833 018 021	1	Gehäuse Housing	33	831 001 168	1	Aufnahmeglocke, Kugellager Retaining cover, ball bearing
24	831 001 126	1	Drahtaustrittsdüse P16, Draht 0.8mm Wire outlet nozzle P16, wire 0.8mm	34	831 007 106	1	Ring Ring
25	305 501 069	1	Zylinderschraube ISO4726-M3x25-A2 Cylinder screw ISO4726-M3x25-A2	35	554 058 373	1	Sicherungsring 78x2.4 Retaining ring 78x2.4
26	565 808 166	1	Zylinderstift ISO2388-2.5M6x32 Cylinder pin ISO2338-2.5M6x32-A2	36	831 018 001	1	Ring Ring
27	305 501 090	4	Zylinderschraube ISO4726-M3x10-A2 Cylinder screw ISO4726-M3x10-A2	37	831 018 002	1	Distanzring Spacer ring
28	831 050 013	1	Flansch Flange	38	302 301 050	2	Senkschraube ISO 10642-M3x6-A2 Countersunk screw ISO 10642-M3x6-A2
29	831 007 065	2	Rillenkugellager SKF 61812 60x78x10 Grooved ball bearing SKF 61812 60x78x10	39	542 500 318	3	Scheibe D4.3 Washer D4.3
30	831 018 003	1	Aluminiumbuchse Aluminium bushing	40	302 505 070	2	Senkschraube ISO 10642-M3x5-A2 Countersunk screw ISO 10642-M3x5-A2

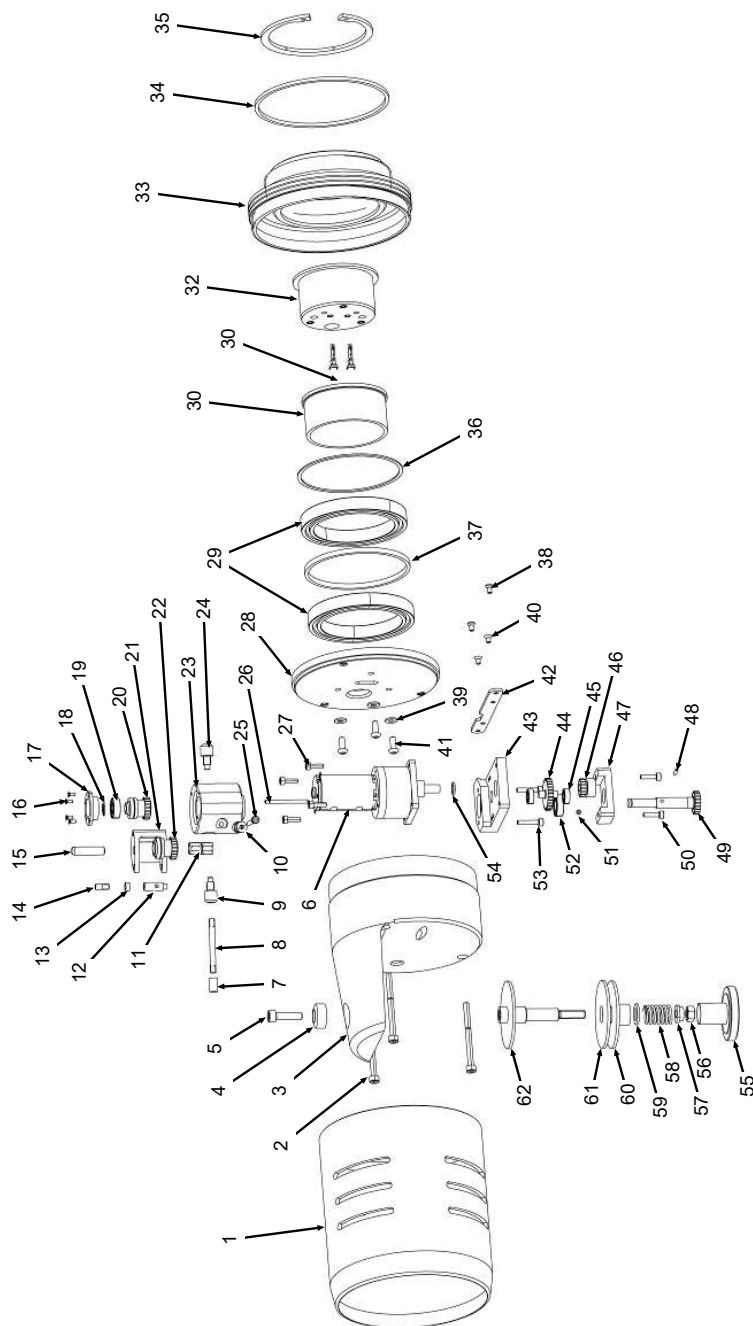

POS. NO.	CODE PART NO.	STK. QTY.	BEZEICHNUNG DESCRIPTION	POS. NO.	CODE PART NO.	STK. QTY.	BEZEICHNUNG DESCRIPTION
41	307 001 112 3		Linsenschraube ISO7380-M4x10-A2 Oval-head screw ISO7380-M4x10-A2	51	445 005 220 1		Gewindestift DIN913-M3x3-A2 Threaded pin DIN913-M3x3-A2
42	831 001 163 1		Haltebügel Mounting bracket	52	831 018 035 1		Kugellager 8x16x5 Ball bearing 8x16x5
43	831 018 012 1		Getriebemotor, Halterung Gear motor, holder	53	305 501 060 2		Zylinderschraube ISO4762-M3x16-A2 Cylinder screw ISO4762-M3x16-A2
44	831 018 024 1		Zahnrad Gear wheel	54	831 018 013 1		Scheibe Washer
45	831 001 049 2		Kugellager (5x11x4mm) Ball bearing (5x11x4mm)	55	833 001 002 1		Rändelscheibe Knurled washer
46	831 050 015 1		Zahnrad, Drahtmotor Gear wheel, wire motor	56	500 602 316 1		Sechskantmutter ISO4032-M6-Ik-A2 Hexagon nut ISO4032-M6-Ik-A2
47	831 018 010 1		Haltebügel Mounting bracket	57	833 101 8027	1	Spezialmutter (Linksgewinde) Special nut (left thread)
48	565 808 170 1		Zylinderstift ISO2338-2M6x10-A2 Cylindrical pin ISO2338-2M6x10-A2	58	831 018 028 1		Feder Spring
49	831 018 011 1		Zahnwelle Splined shaft	59	831 018 029 1		Scheibe Washer
50	305 501 055 2		Zylinderschraube ISO4762-M3x12-A2 Cylinder screw ISO4762-M3x12-A2	60	831 050 016 1		Kupplungsscheibe Clutch disc

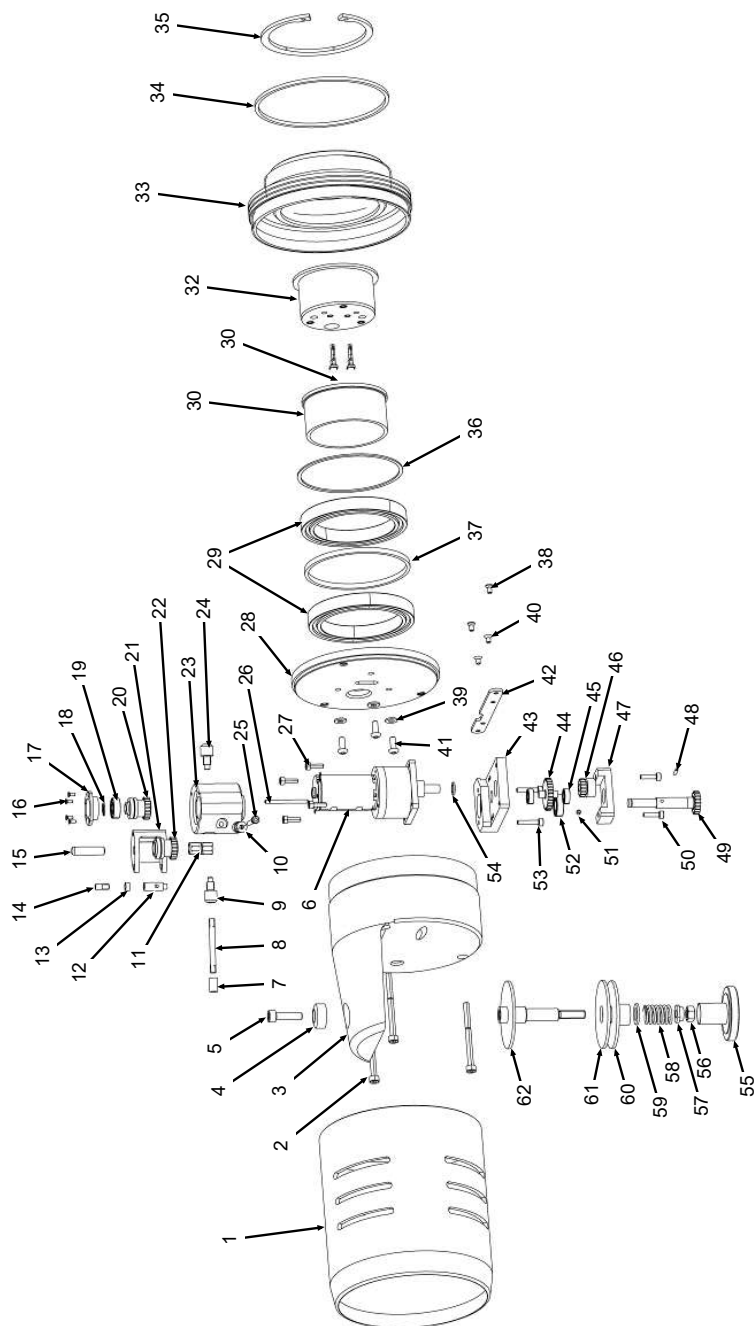

POS. NO.	CODE PART NO.	STK. QTY.	BEZEICHNUNG DESCRIPTION
61	840 001 006	1	Kupplung Clutch
62	833 050 014	1	Welle Drahtspule, komplett Shaft wire coil, complete

# 11.9 Drahtverstellgruppe P16 EVO, kpl. | Wire adjustment group P16, complete

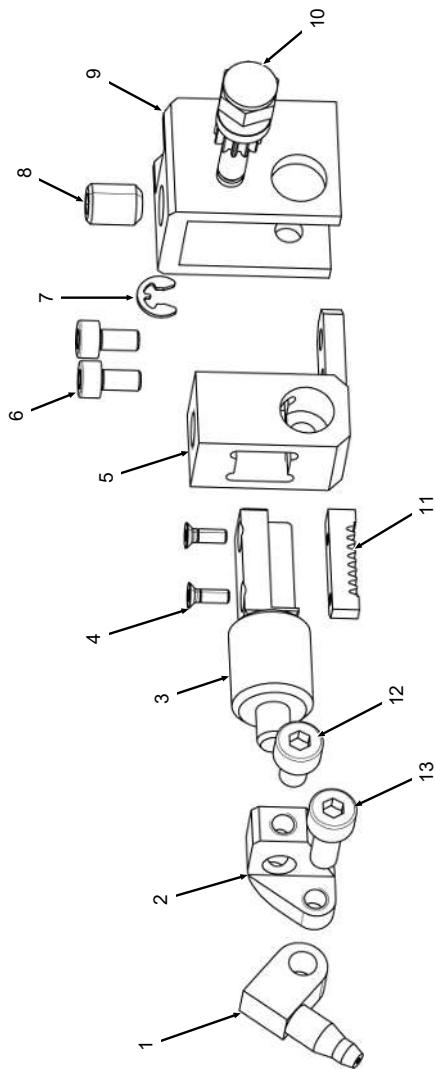



POS. NO.	CODE PART NO.	STK. QTY.	BEZEICHNUNG DESCRIPTION	POS. NO.	CODE PART NO.	STK. QTY.	BEZEICHNUNG DESCRIPTION
1	831 001 031	1	Drahtdüse P16, Draht 0.8 mm Wire nozzle P16, wire 0.8 mm	11	831 001 130	1	Zahnstange P 16 Rack P16
2	831 001 137	1	Drahtdüse, Halterung P16 Wire nozzle, support P16	12	305 501 066	1	Zylinderschraube ISO4762-M4x6-A2 Cylinder screw ISO4762-M4x6-A2
3	831 001 145	1	Stift mit Zahnstangenhalterung Pin with gear rack support	13	305 501 067	1	Zylinderschraube ISO4762-M4x10-A2 Cylinder screw ISO4762-M4x10-A2
4	302 000 040	2	Senkschraube ISO7046-1-M2x6-A2 Countersunk screw ISO7046-1-M2x6-A2				
5	831 001 138	1	Schlitten, Drahtverstellung P16 Slide, wire adjustment P16				
6	305 501 065	2	Zylinderschraube ISO4762-M3x6-A2 Cylinder screw ISO4762-M3x6-A2				
7	831 001 046	1	Sicherungsscheibe DIN6799 3.2 Treaded spindle				
8	445 005 212	1	Gewindestift DIN913-M6x8-45H-ZN Grub screw DIN913-M6x8-45H-ZN				
9	831 001 128	1	Isolierung P16 Insulation P16				
10	831 001 129	1	Welle, Zahnstift P16 Shaft, pin 16				

**11.10 P16 EVO: Schläuche, Kabel und Anschlüsse | P16 EVO: Hoses, cables and connectors**

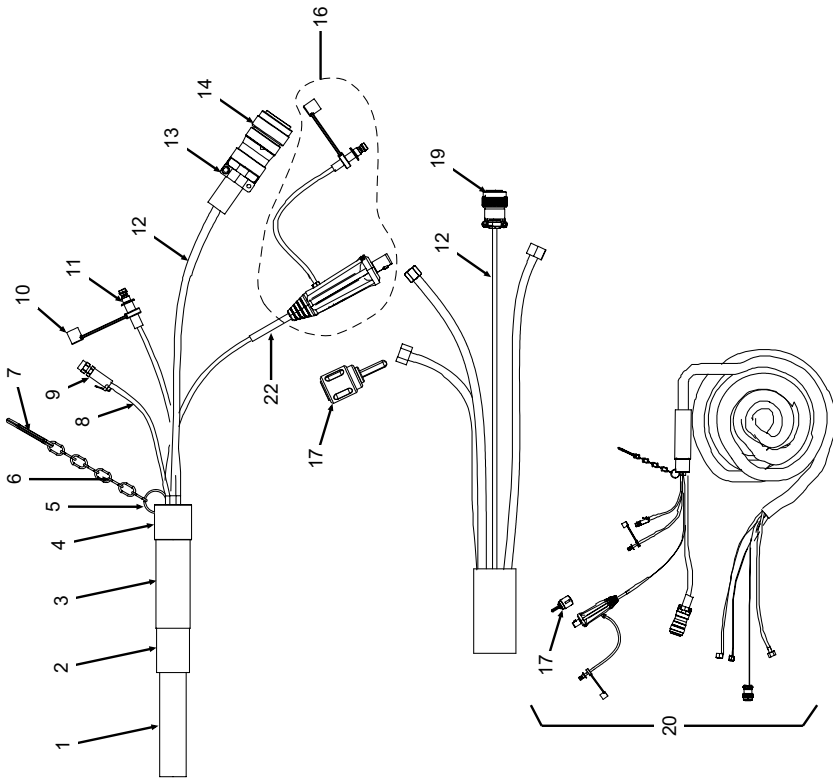

POS. NO.	CODE PART NO.	STK. QTY.	BEZEICHNUNG DESCRIPTION	POS. NO.	CODE PART NO.	STK. QTY.	BEZEICHNUNG DESCRIPTION
1	823 020 009	7,5 m	Kabelschutzschlauch Ø25 mm Cable protection hose Ø25 mm	11	875 020 045	0,17 m	Schrumpfschlauch 12,7x6,4 Shrinking tube 12,7x6,4
2	823 020 011	1	Kaltschrumpfschlauch Ø35 mm Cold shrink hose Ø35 mm	12	823 012 011	8,5 m	Steuerleitung 12x0,25 qmm Signal cable 12x0,25 qmm
3	823 020 012	1	Kaltschrumpfschlauch Ø30 mm Cold shrink hose Ø30 mm	13	885 012 015	1	Zugentlastung für Amphenolstecker Strain relief for amphenol plug
4	823 005 009	1	Zugentlastung Schlauchpaket Strain relief hose package	14	885 012 014	1	Amphenol Kabelstecker 24pol. Amphenol cable connector 24-pole
5	823 020 013	1	Karabinerhaken Schlauchpaket Snap hook hose package	16	831 005 002	1	Stecker TIG50 Plug TIG50
6	823 005 004	1	Befestigungskette Schlauchpaket 0,12m Fastening chain hose package 0,12m	17	850 030 002	1	Adapter für Stecker 180SW + Adapter male connector 180SW +
7	823 005 005	1	Schlüsselring Schlauchpaket Key ring cable assembly	19	832 007 038	1	Amphenol Kabelbuchse 19pol. Amphenol cable bushing 19- pole
8	823 020 061	7,5 m	Teflonschlauch OW/OW S Teflonschlauch OW/OW S	20	833 001 016	1	Schlauchpaket P16, komplett Cable assembly P16, complete
9	823 020 014	1	Schnellverschluss Gasstecker Self sealing coupling gas male	21	831 001 164	1	Werkzeugset P16 (AVC)/P20 Tool set P16 (AVC)/P20
10	823 020 019	1	Wasserverschlussstopfen (blau) Water sealing plug (blue)	22	875 020 058	0,2 m	Schrumpfschlauch 18 x 6 rot Shrink tube 18 x 6 red

**11.11 P16 EVO AVC: Schläuche, Kabel und Anschlüsse | P16 EVO AVC:  
Hoses, cables and connectors**

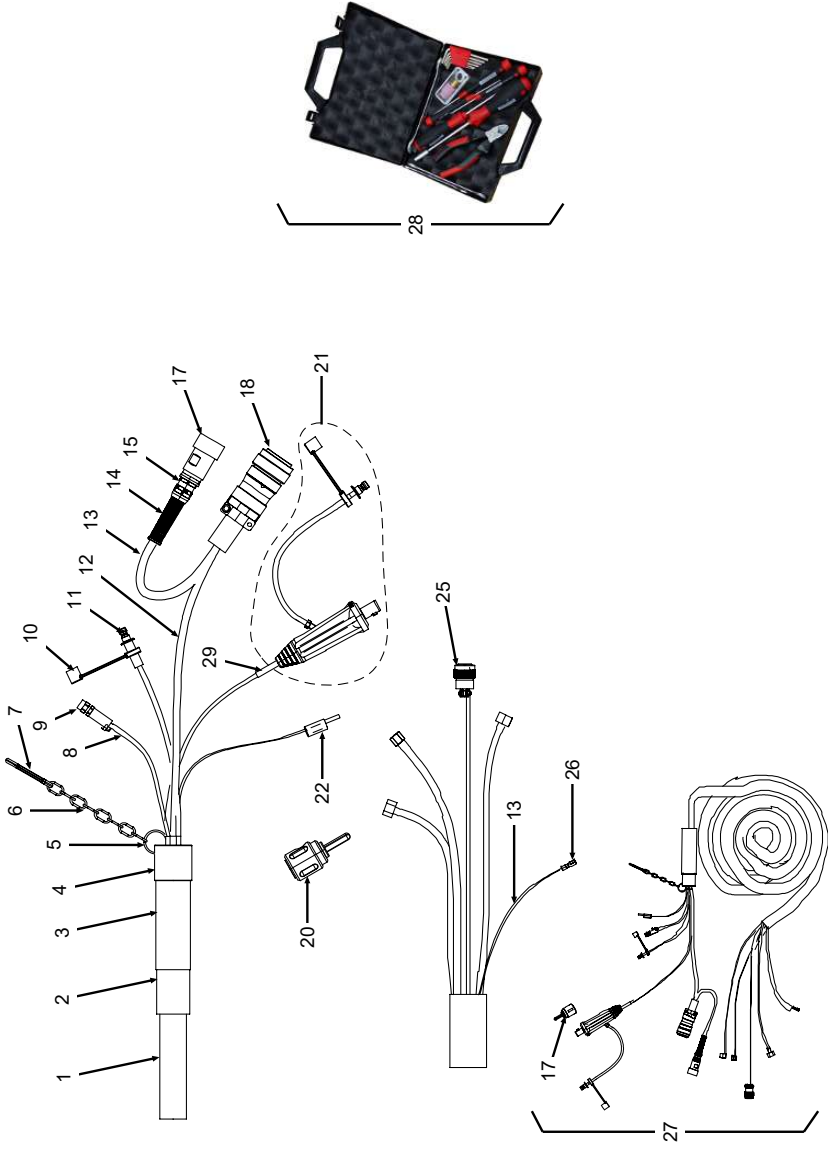

POS. NO.	CODE	STK. QTY.	BEZEICHNUNG DESCRIPTION	POS. NO.	CODE PART NO.	STK. QTY.	BEZEICHNUNG DESCRIPTION
1	823 020 009	7,5m	Kabelschutzschlauch Ø25 mm Cable protection hose Ø25 mm	11	875 020 045	0,17 m	Schrumpfschlauch 12,7x6,4 Shrinking tube 12,7x6,4
2	823 020 011	1	Kaltschrumpfschlauch Ø35 mm Cold shrink hose Ø35 mm	12	823 012 011	8,5 m	Steuerleitung 12x0,25 qmm Signal cable 12x0,25 qmm
3	823 020 012	1	Kaltschrumpfschlauch Ø30 mm Cold shrink hose Ø30 mm	13	831 005 003	1	Steuerleitung 12x0,25 qmm L400 Signal cable 12x0,25 qmm L400
4	823 005 009	1	Zugentlastung Schlauchpaket Strain relief hose package	14	860 012 071	1	Biegeschutz Bending protection
5	823 020 013	1	Karabinerhaken Schlauchpaket Snap hook hose package	15	860 012 041	1	Reduzierung Reduction
6	823 005 004	1	Befestigungskette Schlauchpaket 0,12m Fastening chain hose package 0,12m	16	885 012 015	1	Zugentlastung Amphphenolkabelstecker 24pol. Strain relief amphenol plug 24-pole
7	823 005 005	1	Schlüsselring Schlauchpaket Key ring cable assembly	17	812 012 058	1	Anschlussstecker Steuerleitung AVC/OSC Plug connector signal cable AVC/OSC
8	823 020 061	7,5 m	Teflonschlauch OW/OW S Teflon hose OW/OW S	18	885 012 014	1	Amphenol Kabel-Stecker 24pol. Amphenol cable connector 24-pole
9	823 020 014	1	Schnellverschluss Gasstecker Self sealing coupling gas male	20	850 030 002	1	Adapter für Stecker 180SW + Adapter male connector 180SW +
10	823 020 019	1	Wasserverschlussstopfen (blau) Water sealing plug (blue)	21	831 005 002	1	Stecker TIG50 Plug TIG50

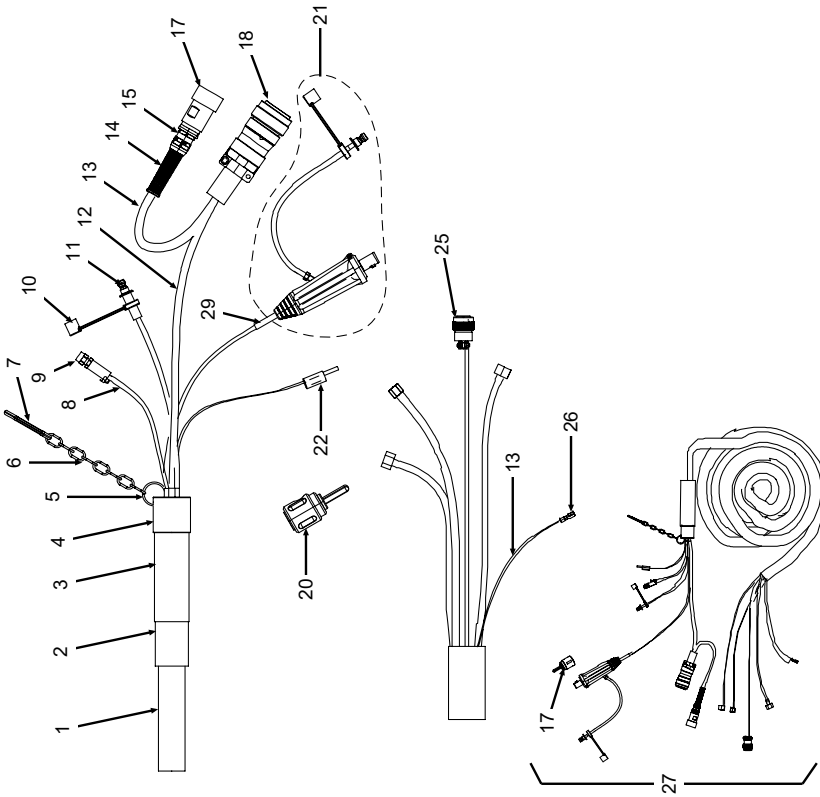

POS. NO.	CODE PART NO.	STK. QTY.	BEZEICHNUNG DESCRIPTION	POS. NO.	CODE PART NO.	STK. QTY.	BEZEICHNUNG DESCRIPTION
22	812 012 054	1 m	Messstecker schwarz AVC Measurement plug black AVC				
23	812 012 056	8 m	Messleitung 1,5qmm AVC/OSC Measuring line 1,5qmm AVC/OSC				
25	832 007 038	1	Amphenol Kabelbuchse 19pol. Amphenol cable bushing 19-pole				
26	790 142 524	1	Flachstecker Flat plug				
27	833 050 083	1	Schlauchpaket P16 AVC, komplett Cable assembly P16 AVC, complete				
28	831 001 164	1	Werkzeugset P16 (AVC)/P20 Tool set P16 (AVC)/P20				
29	875 020 058	0,2 m	Schrumpfschlauch 18 x 6 rot Shrink tube 18 x 6 red				

# 12 Declaration of Conformity

## ORIGINAL

de **EG-Konformitätserklärung**  
 en **EC Declaration of conformity**  
 fr **CE Déclaration de conformité**  
 it **CE Dichiarazione di conformità**  
 es **CE Declaración de conformidad**  
 nl **EG-conformiteitsverklaring**  
 cz **ES Prohlášení o shodě**  
 sk **EÚ Prehlásenie o zhode**  
 pl **Deklaracja zgodności WE**



Orbitalum Tools GmbH  
 Josef-Schüttler-Straße 17  
 78224 Singen, Deutschland  
 Tel. +49 (0) 77 31 792-0

Maschine und Typ (inklusive optional erhältlichen Zubehöartikeln von Orbitalum): / Machinery and type (including optionally available accessories from Orbitalum): / Machine et type (y compris accessoires Orbitalum disponibles en option): / Macchina e tipo (inclusi gli articoli accessori acquistabili opzionalmente da Orbitalum): / Máquina y tipo (incluidos los artículos de accesorios de Orbitalum disponibles opcionalmente): / Machine en type (inclusief optioneel verkrijgbare accessoires van Orbitalum): / Stroj a typ stroje (včetně volitelného příslušenství firmy Orbitalum): / Stroj a typ (vrátane voliteľne dostupného príslušenstva od Orbitalum): / Maszyna i typ (wraz z opcjonalnie dostępnymi akcesoriami firmy Orbitalum):

**Rohreinschweißköpfe**  
 (\*inkl. Orbitalschweißstromquelle):

- P16 EVO
- P16 EVO mit Kaltdraht
- P16 EVO AVC mit Kaltdraht

Seriennummer: / Series number: / Nombre de série: / Numero di serie: / Número de serie: / Seriennummer: / Sériové číslo: / Sériové číslo / :Numer serijny

Baujahr: / Year: / Année: / Anno: / Año: / Bouwjaar: / Rok výroby: / Rok výroby:

Hiermit bestätigen wir, dass die genannte Maschine entsprechend den nachfolgend aufgeführten Richtlinien gefertigt und geprüft worden ist: / Herewith our confirmation that the named machine has been manufactured and tested in accordance with the following standards: / Par la présente, nous déclarons que la machine citée ci-dessus a été fabriquée et testée en conformité aux directives: / Con la presente confermiamo che la macchina sopra specificata è stata costruita e controllata conformemente alle direttive qui di seguito elencate: / Por la presente confirmamos que la máquina mencionada ha sido fabricada y comprobada de acuerdo con las directivas especificadas a continuación: / Hiermee bevestigen wij, dat de vermelde machine in overeenstemming met de hieronder vermelde richtlijnen is gefabriceerd en gecontroleerd: / Tímto potvrzujeme, že uvedený stroj byl vyroben a testován v souladu s níže uvedenými směrnici: / Tymto potvrdzujeme, że uvedený stroj był zhotowený a odskušany podľa nižšie uvedených smerníc: / Niniejszym potwierdzamy, że powyższa maszyna została wyprodukowana i przetestowana zgodnie z wymienionymi poniżej wytycznymi:

- **Maschinen-Richtlinie 2006/42/EG**
- **EMV-Richtlinie 2014/30/EU**
- **RoHS-Richtlinie 2011/65/EU**

Schutzziele folgender Richtlinien werden eingehalten: / Protection goals of the following guidelines are observed: / Les objectifs de protection des directives suivantes sont respectés: / Gli obiettivi di protezione delle seguenti linee guida sono rispettati: / Se observan los objetivos de protección de las siguientes directrices: / De beschermingsdoelstellingen van de volgende richtlijnen worden in acht genomen: / Jsou splněny ochranné cíle těchto nařízení: / Sú splnené ochranné ciele týchto nariadení / Cele ochronne następujących dyrektyw są spełnione:

- **Niederspannungsrichtlinie 2014/35/EU**

Folgende harmonisierte Normen sind angewandt: / The following harmonized norms have been applied: / Les normes suivantes harmonisées ont été appliquées: / Le seguenti norme armonizzate oye applicabili: / Las siguientes normas armonizadas han sido aplicadas: / Onderstaande geharmoniseerde normen zijn toegepast: / Jsou použity následující harmonizované normy: / Boli aplikované tieto harmonizované normy: / Stosowane są następujące normy zharmonizowane:

- **EN ISO 12100:2010**
- **EN ISO 13849-1:2015**
- **EN ISO 13849-2:2012**
- **EN 60204-1:2018**
- **EN IEC 60974-1:2018+A1:2019**
- **EN 60974-10:2014+A1:2015**
- **EN 60204-1:2018**

Bevollmächtigt für die Zusammenstellung der technischen Unterlagen: / Authorised to compile the technical file: / Autorisé à compiler la documentation technique: / Incaricato della redazione della documentazione tecnica: / Autorizado para la elaboración de la documentación técnica: / Gemachtigde voor het samenstellen van het technisch dossier: / Osoba zplnomocněná k sestavení technické dokumentace: / Spilnomocnenc nez zostavenie technických podkladov: / Uprawniony do sporządzania dokumentacji technicznej:

**Gerd Riegaf**  
**Orbitalum Tools GmbH**  
**D-78224 Singen**

Bestätigt durch: / Confirmed by: / Confirmé par: / Confermato da: / Confirmando por: / Bevestigd door: / Potvrdil: / Potvrtil: / Bestätigt durch:

Singen, 22.06.2023:

Jürgen Jäckle - Product Compliance Manager



**ORIGINAL**

de UKCA-Konformitätserklärung  
 en UKCA Declaration of conformity



Orbitalum Tools GmbH  
 Josef-Schüttler-Straße 17  
 78224 Singen, Deutschland  
 Tel. +49 (0) 77 31 792-0

Maschine und Typ (inklusive optional erhältlichen Zubehörtartikeln von Orbitalum): /  
 Machinery and type (including optionally available accessories from Orbitalum):

Rohreinschweißköpfe  
 ("inkl. Orbitalschweißstromquelle)  
 Tube-to-tube-sheet orbital weld heads  
 ("incl. orbital welding power source):  
 • P16 EVO  
 • P16 EVO KD  
 • P16 EVO AVC mit KD

Seriennummer: / Series number:

Baujahr: / Year:

Hiermit bestätigen wir, dass die genannte Maschine entsprechend den nachfolgend  
 aufgeführten Richtlinien gefertigt und geprüft worden ist: / Herewith our confirmation that the  
 named machine has been manufactured and tested in accordance with the following  
 regulations:

• S.I. 2008/1597 Supply of Machinery (Safety)  
 • S.I. 2016/1091 Electromagnetic Compatibility  
 • S.I. 2012/3032 Restriction of the Use of Certain  
 Hazardous Substances in Electrical and  
 Electronic Equipment

Schutzziele folgender Richtlinien werden eingehalten: / Protection goals of the following  
 guidelines are observed:

• S.I. 2016/1101 Electrical Equipment (Safety)

Folgende harmonisierte Normen sind angewandt: / The following harmonized standards  
 have been applied:

• EN ISO 12100:2010  
 • EN ISO 13849-1:2015  
 • EN ISO 13849-2:2012  
 • EN 60204-1:2018  
 • EN IEC 60974-1:2018+A1:2019  
 • EN 60974-10:2014+A1:2015  
 • EN 60204-1:2018

Bevollmächtigt für die Zusammenstellung der technischen Unterlagen: / Authorized to  
 compile the technical file:

Bestätigt durch: / Confirmed by:

Singen, 22.06.2023:

Jürgen Jäckle - Product Compliance Manager





Orbitalum Tools GmbH provides global customers one source for the finest in pipe & tube cutting, beveling and orbital welding products.

## worldwide | sales + service

### NORTH AMERICA

#### USA

E.H. Wachs  
600 Knightsbridge Parkway  
Lincolnshire, IL 60069  
USA  
Tel. +1 847 537 8800  
Fax +1 847 520 1147  
Toll Free 800 323 8185

#### Northeast

Sales, Service & Rental Center  
E.H. Wachs  
1001 Lower Landing Road, Suite 208  
Blackwood, New Jersey 08012  
USA  
Tel. +1 856 579 8747  
Fax +1 856 579 8748

#### Southeast

Sales, Service & Rental Center  
E.H. Wachs  
171 Johns Road, Unit A  
Greer, South Carolina 29650  
USA  
Tel. +1 864 655 4771  
Fax +1 864 655 4772

#### Northwest

Sales, Service & Rental Center  
E.H. Wachs  
2079 NE Aloclek Drive, Suite 1010  
Hillsboro, Oregon 97124  
USA  
Tel. +1 503 941 9270  
Fax +1 971 727 8936

#### Gulf Coast

Sales, Service & Rental Center  
E.H. Wachs  
2220 South Philippe Avenue  
Gonzales, LA 70737  
USA  
Tel. +1 225 644 7780  
Fax +1 225 644 7785

#### Houston South

Sales, Service & Rental Center  
E.H. Wachs  
3327 Daisy Street  
Pasadena, Texas 77505  
USA  
Tel. +1 713 983 0784  
Fax +1 713 983 0703

#### CANADA

Wachs Canada Ltd  
Eastern Canada Sales, Service & Rental  
Center  
1250 Journey's End Circle, Unit 5  
Newmarket, Ontario L3Y 0B9  
Canada  
Tel. +1 905 830 8888  
Fax +1 905 830 6050  
Toll Free: 888 785 2000

Wachs Canada Ltd  
Western Canada Sales, Service & Rental  
Center  
5411 82 Ave NW  
Edmonton, Alberta T6B 2J6  
Canada  
Tel. +1 780 469 6402  
Fax +1 780 463 0654  
Toll Free 800 661 4235

### EUROPE

#### GERMANY

Orbitalum Tools GmbH  
Josef-Schuetzler-Str. 17  
78224 Singen  
Germany  
Tel. +49 (0) 77 31 - 792 0  
Fax +49 (0) 77 31 - 792 500

#### UNITED KINGDOM

Wachs UK  
UK Sales, Rental & Service Centre  
Units 4 & 5 Navigation Park  
Road One, Winsford Industrial Estate  
Winsford, Cheshire CW7 3 RL  
United Kingdom  
Tel. +44 (0) 1606 861 423  
Fax +44 (0) 1606 556 364

### ASIA

#### CHINA

Orbitalum Tools  
New Caohejing International  
Business Centre  
Room 2801-B, Building B  
No 391 Gui Ping Road  
Shanghai 200052  
China  
Tel. +86 (0) 512 5016 7813  
Fax +86 (0) 512 5016 7820

#### INDIA

ITW India Pvt. Ltd  
Plot No.28/22, D-2 Block  
Near KSB Chowk  
MIDC, Chinchwad  
Pune - 411019  
Maharashtra - India  
Mob. +91 (0) 91 00 99 45 7

### AFRICA & MIDDLE EAST

#### UNITED ARAB EMIRATES

Wachs Middle East & Africa  
Operations  
PO Box 262543  
Free Zone South FZS 5, AC06  
Jebel Ali Free Zone (South-5),  
Dubai  
United Arab Emirates  
Tel. +971 4 88 65 211  
Fax +971 4 88 65 212